

# Premium V-Belt Drives



 **TB Wood's**  
Incorporated

*An Altra Industrial Motion Company*

# TB Wood's

TB Wood's is an industry leading designer and manufacturer of mechanical power transmission equipment for industrial control. Our mechanical product lines include: clutch and brake, synchronous and belted variable speed drives; grid, disc, jaw, gear coupling and elastomeric coupling products; sheaves and bushings. Registered trademarks include Sure-Flex®, Dura-Flex®, G-Flex®, and QT Bushings®.

TB Wood's was founded in 1857 and began as a foundry producing wood burning stoves. Our company's tradition of product innovation started early. Wood's entered the power transmission industry at the turn of the century with the introduction of flat belted drives and line shafting.

In April 2007, TB Wood's was purchased by Altra Holdings, Inc. This acquisition placed TB Wood's as part of a larger company with complementary products to help grow the business.



## Altra Industrial Motion

Altra is a leading multinational designer, producer and marketer of a wide range of mechanical power transmission products. We sell our products in over 70 countries throughout the world. Our products are frequently used in critical applications, such as fail-safe brakes for elevators, wheelchairs and forklifts, and in high-volume manufacturing processes, where the reliability and accuracy of our products are critical in both avoiding costly down time and enhancing the overall efficiency of manufacturing operations.

Our products are marketed under a variety of well recognized and established manufacturing brand names. These leading brands are Ameridrives, Boston Gear, Warner Electric, Formsprag Clutch, TB Wood's Incorporated, Industrial Clutch, Kilian Manufacturing, Marland Clutch, Nuttall Gear, Stieber Clutch, Twiflex Ltd, Huco Dynatork, Bibby Transmissions, Matrix International, Inertia Dynamics, Delroyd Worm Gear, Warner Linear and Wichita Clutch.

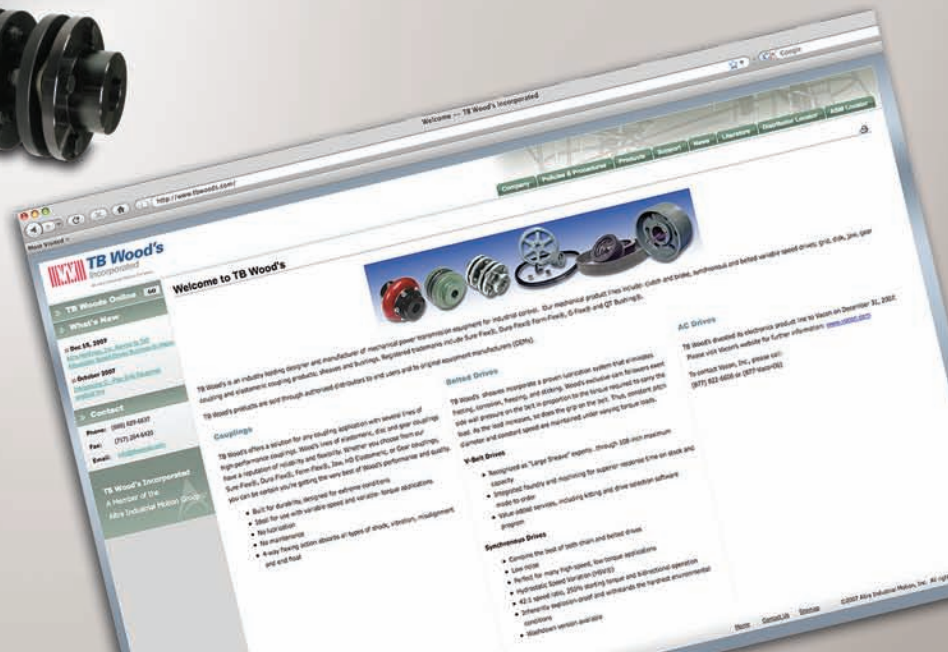

Visit us on the web at  
**tbwoods.com**



## The Premium Advantage

Premium V-belts can handle 1.4 to 2.2 times more horsepower than the equivalent size standard V-belt. So you can design a more compact drive that weighs less, puts less strain on costlier components, and uses fewer belts as shown in the following example.

### Standard

6 Strand 5V drive; Rated HP/Strand: 32.9  
 Total weight: 265 lbs.

### Premium

3 Strand 5VP drive; Rated HP/Strand: 66.8  
 Total weight: 153 lbs

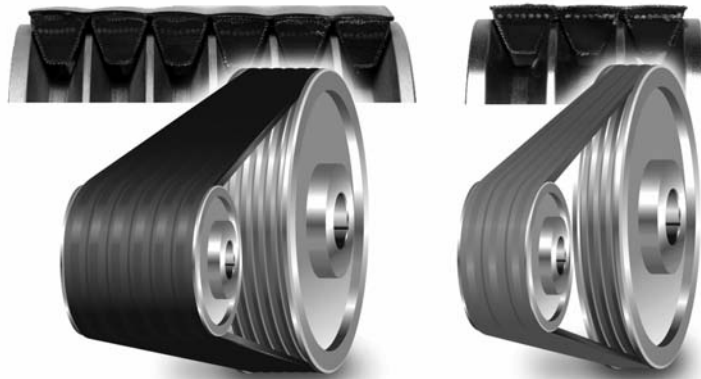

## The Premium belt difference is in the construction

### “Clutching” non-rubber surfaced cover

Allows momentary slippage due to excessive overloads without burning belts up

### KEVLAR\* or aramid tensile cords

Give extraordinary strength, durability and virtually zero stretch

### Virtually zero stretch

Eliminates the need for constant belt re-tensioning

### Chloroprene rubber compounds

Provide superb oil and heat resistance

### Specially-treated extra tough cover

Withstands slip and shear forces at peak loads without generating excessive heat; fends off penetration by foreign materials

### Curve design

Compensate for effects such as sidewall bulge, which occur when belts bend around a sheave. This yields uniform loading, giving maximum belt life and even wear on the sheave sidewalls (eliminates dishing)

### Double fabric cover

Creates maximum abrasion resistance that protects against wear caused by fine airborne dust in rock quarries and lumber mills, which can cause rapid belt sidewall wear resulting in early failures

### Over 20-50 percent more horsepower than standard V-Belts

Enables new equipment designers to utilize the full load-carrying capacity of these high-performance belts

\*Kevlar® is a registered trademark of Dupont™

# Table of Contents

Section		Pages
<b>BP1</b>	<b>Narrow Premium Drives</b>	Sure Grip Sheaves .....2-3 Ultra-V Sheaves .....4-10 V-Belt Features .....11 Single and Banded Belts .....12-14 Drive Selection .....15-17 Balancing Standards .....18 Drive Selection/Drive Design .....19 Horsepower Ratings .....20-23
<b>BP2</b>	<b>Classical Premium Drives</b>	Sure Grip Sheaves .....2 Classical Sheaves .....3-10 V-Belt Features .....11 Classical V-Belts .....12 Drive Selection .....13-15 Balancing Standards .....16-17 APR Belts Horsepower Ratings .....18-19 BPR Belts Horsepower Ratings .....20-21 CPR Belts Horsepower Ratings .....22-23
<b>A1</b>	<b>Wood's Sure-Grip™ QD Bushings</b>	Standard QD .....2-7 "L" Flangeless .....8-9 Short QD Type .....10-11 Tensioners for Idlers .....12 Idler Bushings .....13 Installation Instructions .....14

# Narrow (Premium-V) Drives

**BP1**

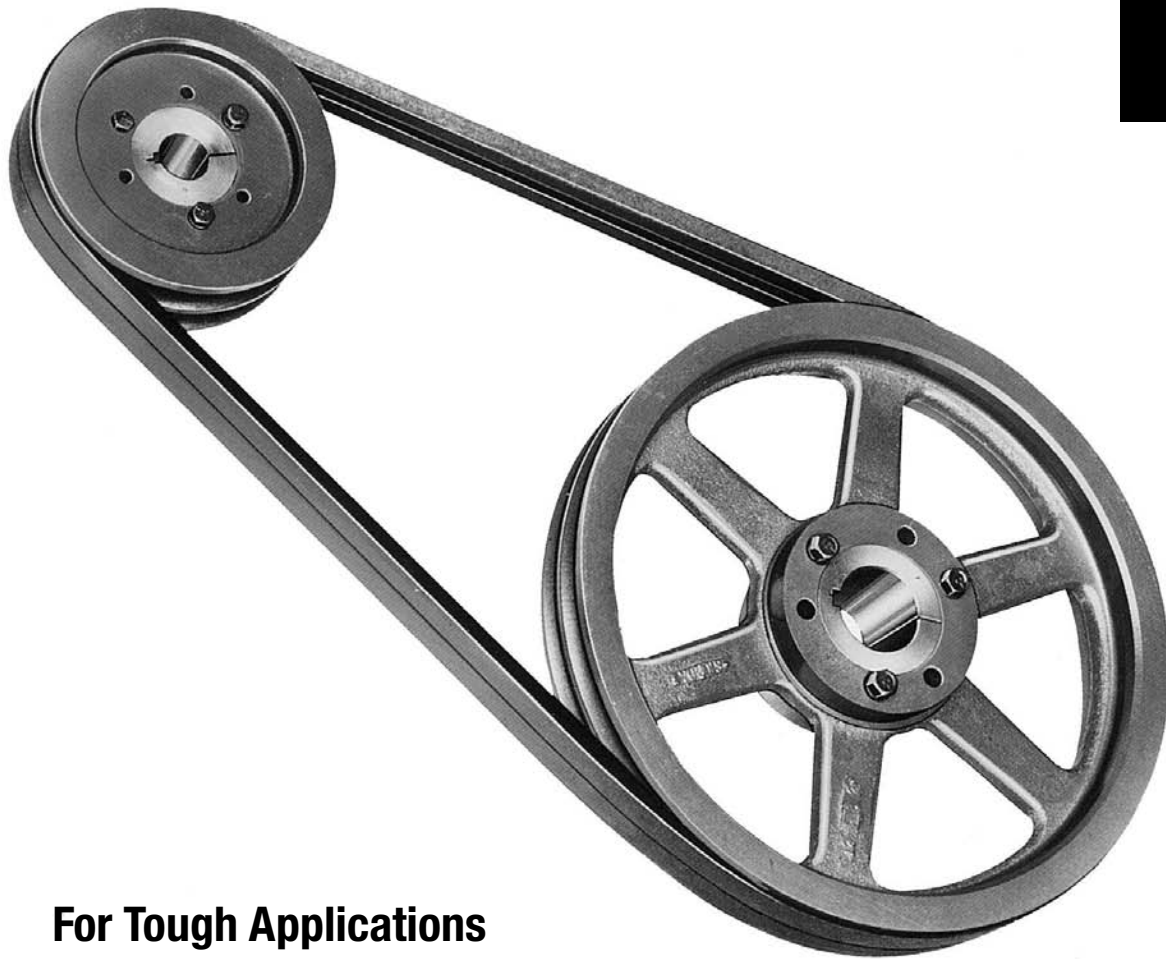

**For Tough Applications**

## **NARROW (Ultra-V) SHEAVE FEATURES**

Wood's Ultra-V sheaves are constructed of fine grain, high tensile cast iron, and have been carefully engineered to assure maximum performance over a long life span. Behind each sheave is one of the most extensive engineering design and testing programs in the industry.

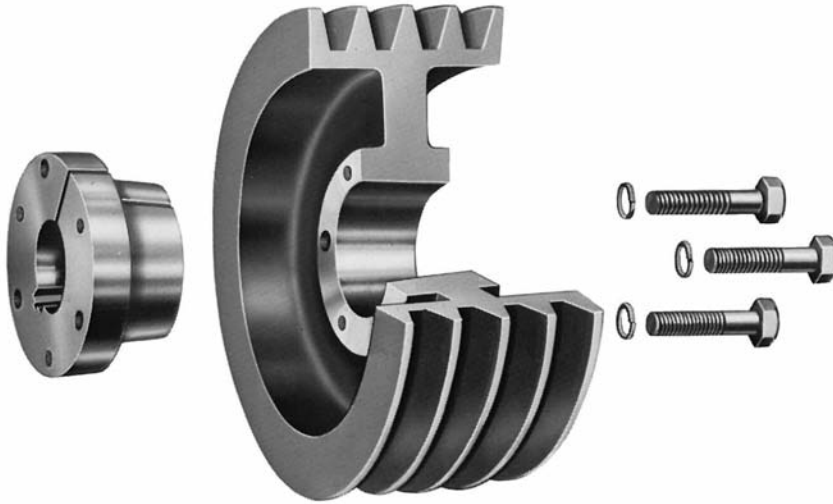

With the advent of higher V-belt ratings, Wood's engineers instituted additional careful test programs to ensure that each Wood's sheave would be capable of safely and dependably delivering the increased performance which was required by the new ratings. Wood's engineers, using a special strain gage test stand, subject sheaves to tension and compression stresses far in excess of those encountered in actual operation.

In another standard test procedure, Wood's sheaves are operated at extremely high speeds. Sheaves are selected from warehouse stocks and tested until they are burst by centrifugal force. Such destructive testing allows Wood's engineers to study the effects of construction and balance on sheave performance. The goal is to assure safe operation at normal speeds. Other continuing programs check product quality in the laboratory and on the manufacturing line.

For applications with special requirements, Wood's sheaves are also available on a made-to-order basis in either cast or ductile iron, and in Sure-Grip or bored-to-suit construction.

Wood's stock narrow sheaves are available with the convenient Sure-Grip QD type bushing. Easy to install and remove, these split, tapered bushings grip the shaft with the equivalent of a shrink fit. This tight holding power eliminates freezing and fretting corrosion between the shaft and the bore and assures quick removal and interchangeability when necessary.

Stock sheaves are designed to carry the loads of all belts shown in this catalog and other similarly rated V-Belts. For special higher rated V-Belts, consult Wood's Engineering Department for recommendations.

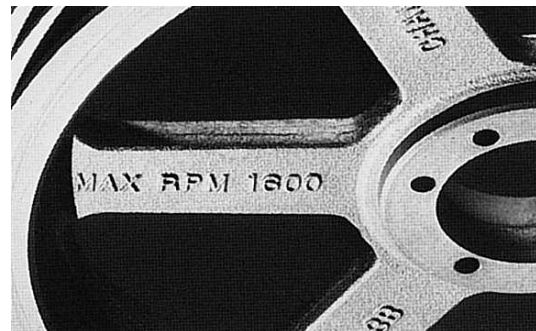

**We cast or stamp the maximum safe operating speed, in rpm, on all sheaves we manufacture.**

# NARROW (Ultra-V) SHEAVE GROOVE DETAILS

## STANDARD GROOVE DIMENSIONS

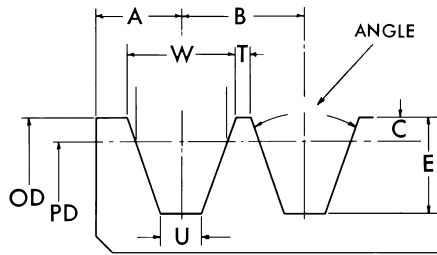

Belt	GROOVE DIMENSIONS IN INCHES								
	A	B	C	E	W	T	U	Angle of Groove	Used on O.D.
3V	1 <sup>1</sup> / <sub>32</sub>	1 <sup>3</sup> / <sub>32</sub>	0	.350	.350	.056	.123	36	Under 3.5
							.109	38	3.5 to 6.0
							.095	40	6.01 to 12.0
							.081	42	12.01, Over
5V	1/2	1 <sup>1</sup> / <sub>16</sub>	0	.600	.600	.0875	.187	38	Under 10.0
							.163	40	10.0 to 16.0
							.139	42	16.01, Over
8V	3/4	1 <sup>1</sup> / <sub>8</sub>	0	1.000	1.000	.125	.312	38	Under 16.0
							.272	40	16.0 to 22.4
							.232	42	22.41, Over

## STANDARD SHEAVE FACE WIDTHS

Belt	1	2	3	4	5	6	7	8	9	10	11	12	13	14	15	16	17	18	For Each Additional Groove Add
3V	1 <sup>1</sup> / <sub>16</sub> *	1 <sup>3</sup> / <sub>32</sub>	1 <sup>1</sup> / <sub>2</sub>	1 <sup>29</sup> / <sub>32</sub>	2 <sup>9</sup> / <sub>16</sub>	2 <sup>23</sup> / <sub>32</sub>	3 <sup>1</sup> / <sub>8</sub>	3 <sup>17</sup> / <sub>32</sub>	3 <sup>15</sup> / <sub>16</sub>	4 <sup>11</sup> / <sub>32</sub>	4 <sup>3</sup> / <sub>4</sub>	5 <sup>5</sup> / <sub>32</sub>	5 <sup>9</sup> / <sub>16</sub>	5 <sup>31</sup> / <sub>32</sub>	6 <sup>3</sup> / <sub>8</sub>	6 <sup>25</sup> / <sub>32</sub>	7 <sup>3</sup> / <sub>16</sub>	7 <sup>19</sup> / <sub>32</sub>	1 <sup>3</sup> / <sub>32</sub>
5V	1	1 <sup>11</sup> / <sub>16</sub>	2 <sup>3</sup> / <sub>8</sub>	3 <sup>1</sup> / <sub>16</sub>	3 <sup>3</sup> / <sub>4</sub>	4 <sup>7</sup> / <sub>16</sub>	5 <sup>1</sup> / <sub>8</sub>	5 <sup>13</sup> / <sub>16</sub>	6 <sup>1</sup> / <sub>2</sub>	7 <sup>3</sup> / <sub>16</sub>	7 <sup>7</sup> / <sub>8</sub>	8 <sup>9</sup> / <sub>16</sub>	9 <sup>1</sup> / <sub>4</sub>	9 <sup>15</sup> / <sub>16</sub>	10 <sup>5</sup> / <sub>8</sub>	11 <sup>5</sup> / <sub>16</sub>	12	12 <sup>11</sup> / <sub>16</sub>	1 <sup>1</sup> / <sub>16</sub>
8V**	1 <sup>1</sup> / <sub>2</sub>	2 <sup>5</sup> / <sub>8</sub>	3 <sup>3</sup> / <sub>4</sub>	4 <sup>7</sup> / <sub>8</sub>	6	7 <sup>1</sup> / <sub>8</sub>	8 <sup>1</sup> / <sub>4</sub>	9 <sup>3</sup> / <sub>8</sub>	10 <sup>1</sup> / <sub>2</sub>	11 <sup>5</sup> / <sub>8</sub>	12 <sup>3</sup> / <sub>4</sub>	13 <sup>7</sup> / <sub>8</sub>	15	16 <sup>1</sup> / <sub>8</sub>	17 <sup>1</sup> / <sub>4</sub>	18 <sup>3</sup> / <sub>4</sub>	19 <sup>7</sup> / <sub>8</sub>	21	1 <sup>1</sup> / <sub>8</sub>

\* For 10.6 to 13.9 outside diameters face width = 3/4". For outside diameters 14.0 and over face width = 13/16.

\*\* Sheaves 16 grooves and over have 3/8" additional metal added to overall face width.

## DEEP GROOVE DIMENSIONS

Belt	A	B	C	E	W	T	U	Angle of Groove	Used on O.D.
3V	3/8	1/2	.109	.459	.421	.079	.123	36	Under 3.72
					.425	.075	.109	38	3.72 to 6.22
					.429	.071	.095	40	6.23 to 12.22
					.434	.067	.081	42	12.22, Over
5V	9/16	1 <sup>3</sup> / <sub>16</sub>	.160	.760	.710	.102	.187	38	Under 10.32
					.716	.096	.163	40	10.32 to 16.32
					.723	.090	.139	42	16.32, Over
8V	2 <sup>7</sup> / <sub>32</sub>	1 <sup>5</sup> / <sub>16</sub>	.262	1.262	1.180	.132	.312	38	Under 16.52
					1.191	.123	.272	40	16.52 to 22.92
					1.201	.113	.232	42	22.92, Over

## DEEP GROOVE SHEAVE FACE WIDTHS

Belt	1	2	3	4	5	6	7	8	9	10	11	12	13	14	15	16	17	18	For Each Additional Groove Add
3V	3/4	1 <sup>1</sup> / <sub>4</sub>	1 <sup>3</sup> / <sub>4</sub>	2 <sup>1</sup> / <sub>4</sub>	2 <sup>3</sup> / <sub>4</sub>	3 <sup>1</sup> / <sub>4</sub>	3 <sup>3</sup> / <sub>4</sub>	4 <sup>1</sup> / <sub>4</sub>	4 <sup>3</sup> / <sub>4</sub>	5 <sup>1</sup> / <sub>4</sub>	5 <sup>3</sup> / <sub>4</sub>	6 <sup>1</sup> / <sub>4</sub>	6 <sup>3</sup> / <sub>4</sub>	7 <sup>1</sup> / <sub>4</sub>	7 <sup>3</sup> / <sub>4</sub>	8 <sup>1</sup> / <sub>4</sub>	8 <sup>3</sup> / <sub>4</sub>	9 <sup>1</sup> / <sub>4</sub>	1/2
5V	1 <sup>1</sup> / <sub>8</sub>	1 <sup>15</sup> / <sub>16</sub>	2 <sup>3</sup> / <sub>4</sub>	3 <sup>3</sup> / <sub>16</sub>	4 <sup>3</sup> / <sub>8</sub>	5 <sup>3</sup> / <sub>16</sub>	6	6 <sup>13</sup> / <sub>16</sub>	7 <sup>5</sup> / <sub>8</sub>	8 <sup>7</sup> / <sub>16</sub>	9 <sup>1</sup> / <sub>4</sub>	10 <sup>1</sup> / <sub>16</sub>	10 <sup>7</sup> / <sub>8</sub>	11 <sup>11</sup> / <sub>16</sub>	12 <sup>1</sup> / <sub>2</sub>	13 <sup>5</sup> / <sub>16</sub>	14 <sup>1</sup> / <sub>8</sub>	14 <sup>15</sup> / <sub>16</sub>	1 <sup>3</sup> / <sub>16</sub>
8V	1 <sup>11</sup> / <sub>16</sub>	3	4 <sup>5</sup> / <sub>16</sub>	5 <sup>5</sup> / <sub>8</sub>	6 <sup>15</sup> / <sub>16</sub>	8 <sup>1</sup> / <sub>4</sub>	9 <sup>3</sup> / <sub>16</sub>	10 <sup>7</sup> / <sub>8</sub>	12 <sup>3</sup> / <sub>16</sub>	13 <sup>1</sup> / <sub>2</sub>	14 <sup>13</sup> / <sub>16</sub>	16 <sup>1</sup> / <sub>8</sub>	17 <sup>7</sup> / <sub>16</sub>	18 <sup>3</sup> / <sub>4</sub>	20 <sup>1</sup> / <sub>16</sub>	21 <sup>3</sup> / <sub>8</sub>	22 <sup>11</sup> / <sub>16</sub>	24	1 <sup>5</sup> / <sub>16</sub>

These sheaves are designed to carry the loads of all belts shown in this catalog and other similarly rated V-Belts. For special higher rated V-Belts, consult Wood's Engineering Department for recommendations.

The sheaves listed below are all stock sizes. The dimensions given are with the Sure-Grip bushings in place. When ordering, specify the bushing, if required, and the bore size. The figure following the letter in the "Type" column indicates the sheave construction: 1 – Solid, 2 – Web, 3 – Arms.

### DIMENSIONS (In Inches)

O.D. ◆	I.D.	Product No.	1 GROOVE							Product No.	2 GROOVE						
			*F = 11/16								F = 1-3/32						
			Bush.	Type	E	K	L	M	Wt.		Bush.	Type	E	K	L	M	Wt.
2.20 †	...	3V221	JA	E1	19/32	7/16	1	29/32	0.9	3V222	JA	E1	1	7/16	1	29/32	1.1
2.35 †	...	3V2351	JA	E1	19/32	7/16	1	29/32	1.2	3V2352	JA	E1	1	7/16	1	29/32	1.4
2.50 †	...	3V251	JA	E1	19/32	7/16	1	29/32	1.3	3V252	JA	E1	1	7/16	1	29/32	1.5
2.65	2.00	3V2651	JA	D1	13/32	1/16	1	3/32	0.9	3V2652	JA	D1	11/32	1/8	1	7/16	1.2
2.80	2.00	3V281	JA	D1	13/32	1/16	1	3/32	1.0	3V282	JA	D1	11/32	1/8	1	7/16	1.3
3.00	2.00	3V301	JA	D1	13/32	1/16	1	3/32	1.1	3V302	JA	D1	11/32	1/8	1	7/16	1.5
3.15	2.00	3V3151	JA	D1	13/32	1/16	1	3/32	1.2	3V3152	JA	D1	11/32	1/8	1	7/16	1.7
3.35	2.00	3V3.351	JA	D1	13/32	1/16	1	3/32	1.4	3V3.352	SH	D1	7/16	1/8	1-1/4	9/32	1.9
3.65	2.68	3V3651	SH	C1	9/16	0	1-1/4	0	2.0	3V3652	SH	D1	7/16	1/8	1-1/4	9/32	2.4
4.12	2.88	3V4121	SH	C1	9/16	0	1-1/4	0	2.5	3V4122	SH	D1	1/4	5/16	1-1/4	3/32	2.9
4.50	3.18	3V451	SH	C1	9/16	0	1-1/4	0	3.0	3V452	SH	D1	1/4	5/16	1-1/4	3/32	3.5
4.75	3.44	3V4751	SH	C1	9/16	0	1-1/4	0	3.3	3V4752	SH	D1	1/4	5/16	1-1/4	3/32	3.9
5.00	3.68	3V501	SH	C1	9/16	0	1-1/4	0	3.6	3V502	SH	D1	1/4	5/16	1-1/4	3/32	4.2
5.30	4.00	3V531	SH	C1	9/16	0	1-1/4	0	3.8	3V532	SH	D1	1/4	5/16	1-1/4	3/32	4.7
5.60	4.25	3V561	SH	C1	9/16	0	1-1/4	0	4.2	3V562	SH	D1	1/4	5/16	1-1/4	3/32	5.3
6.00	4.69	3V601	SH	C2	9/16	0	1-1/4	0	4.2	3V602	SH	D2	1/4	5/16	1-1/4	3/32	6.2
6.50	5.25	3V651	SH	C2	9/16	0	1-1/4	0	4.6	3V652	SDS	D1	5/16	5/16	1-5/16	3/32	7.5
6.90	5.62	3V691	SH	C2	9/16	0	1-1/4	0	4.5	3V692	SDS	D2	5/16	5/16	1-5/16	3/32	6.7
8.00	6.68	3V801	SDS	C2	5/8	0	1-5/16	0	7.0	3V802	SDS	D2	5/16	5/16	1-5/16	3/32	7.4
10.60	9.25	3V1061	SDS	D3	5/8	0	1-5/16	1/16	7.4	3V1062	SK	C3	15/32	1/4	1-7/8	5/16	13.1
14.00	12.62	3V1401	SK	C3	21/32	0	1-7/8	11/32	14.4	3V1402	SK	C3	15/32	1/4	1-7/8	5/16	19.6
19.00	17.50	3V1901	SK	C3	21/32	0	1-7/8	11/32	20.6	3V1902	SK	C3	15/32	1/4	1-7/8	5/16	24.2
25.00	...	...	...	...	...	...	...	...	...	3V2502	SF	C3	7/16	1/4	2	15/32	40.7

\*F = 3/4 for 10.60 inches O.D. – F = 13/16 for 14.00 inches and 19.00 inches O.D.

O.D. ◆	I.D.	Product No.	3 GROOVE							Product No.	4 GROOVE						
			F = 1-1/2								F = 1-29/32						
			Bush.	Type	E	K	L	M	Wt.		Bush.	Type	E	K	L	M	Wt.
2.50 †	...	3V253	JA	E1	1-13/32	7/16	1	29/32	1.8	...	...	...	...	...	...	...	...
2.65	2.00	3V2653	JA	E1	27/32	-1/8	1	11/32	1.5	3V2654	JA	E1	1-1/4	-1/8	1	11/32	1.8
2.80	2.00	3V283	JA	E1	27/32	-1/8	1	11/32	1.6	3V284	JA	E1	1-1/4	-1/8	1	11/32	1.9
3.00	1.81	3V303	SH	E1	1-3/16	3/8	1-1/4	15/16	2.3	3V304	SH	E1	1-19/32	3/8	1-1/4	15/16	2.6
3.15	1.81	3V3153	SH	E1	1-3/16	3/8	1-1/4	15/16	2.6	3V3154	SH	E1	1-19/32	3/8	1-1/4	15/16	3.0
3.35	2.68	3V3.353	SH	D1	7/16	1/8	1-1/4	11/16	2.4	3V3.354	SH	D1	7/16	1/8	1-1/4	1-3/32	2.8
3.65	2.68	3V3653	SH	D1	7/16	1/8	1-1/4	11/16	3.0	3V3654	SH	D1	7/16	1/8	1-1/4	1-3/32	3.6
4.12	2.88	3V4123	SH	A1	1/8	11/16	1-1/4	1/8	3.4	3V4124	SH	A1	1/4	13/16	1-1/4	11/32	3.9
4.50	3.31	3V453	SDS	A1	1/16	11/16	1-5/16	1/8	4.1	3V454	SDS	A1	3/16	13/16	1-5/16	13/32	4.5
4.75	3.44	3V4753	SDS	A1	1/16	11/16	1-5/16	1/8	4.6	3V4754	SDS	A1	3/16	13/16	1-5/16	13/32	5.1
5.00	3.68	3V503	SDS	A1	1/16	11/16	1-5/16	1/8	5.0	3V504	SDS	A1	3/16	13/16	1-5/16	13/32	5.6
5.30	4.07	3V533	SDS	A1	1/16	11/16	1-5/16	1/8	5.6	3V534	SDS	A1	3/16	13/16	1-5/16	13/32	6.1
5.60	4.36	3V563	SDS	A1	1/16	11/16	1-5/16	1/8	6.5	3V564	SDS	A1	3/16	13/16	1-5/16	13/32	7.7
6.00	4.69	3V603	SDS	A1	1/16	11/16	1-5/16	1/8	7.0	3V604	SK	D1	3/32	5/8	1-7/8	1/8	9.8
6.50	5.25	3V653	SDS	A2	1/16	11/16	1-5/16	1/8	7.3	3V654	SK	D1	3/32	5/8	1-7/8	1/8	11.3
6.90	5.62	3V693	SDS	A2	1/16	11/16	1-5/16	1/8	7.8	3V694	SK	D1	3/32	5/8	1-7/8	1/8	12.9
8.00	6.68	3V803	SK	D2	15/32	1/4	1-7/8	3/32	10.6	3V804	SK	D2	3/32	5/8	1-7/8	1/8	12.1
10.60	9.25	3V1063	SK	D3	15/32	1/4	1-7/8	3/32	14.7	3V1064	SK	D3	3/32	5/8	1-7/8	1/8	17.3
14.00	12.62	3V1403	SK	D3	15/32	1/4	1-7/8	3/32	21.1	3V1404	SK	D3	3/32	5/8	1-7/8	1/8	24.1
19.00	17.62	3V1903	SF	C3	7/16	1/4	2	1/16	36.3	3V1904	SF	C3	1/16	5/8	2	1/32	39.3
25.00	23.56	3V2503	SF	C3	7/16	1/4	2	1/16	45.0	3V2504	SF	C3	1/16	5/8	2	1/32	58.3
33.50	31.94	3V3353	SF	C3	7/16	1/4	2	1/16	73.8	3V3354	E	C3	13/32	1/2	2-5/8	5/16	106.3

◆ P.D. = O.D. † Recommended for use with Narrow Cog belts only.  
 Weights for all Sure-Grip bushed items are approximate and include the bushing.



# STOCK NARROW (Ultra-V) SHEAVES

# 3V

# TB Wood's Incorporated

An Altra Industrial Motion Company

## DIMENSIONS (In Inches)

O.D. ◆	I.D.	Product No.	5 GROOVE							Product No.	6 GROOVE						
			F = 2-5/16								F = 2-23/32						
			Bush.	Type	E	K	L	M	Wt.		Bush.	Type	E	K	L	M	Wt.
4.75	3.44	3V4755	SDS	A1	3/16	13/16	1-5/16	13/16	5.7	3V4756	SK	E1	1-7/16	1/8	1-7/8	19/32	7.2
5.00	3.68	3V505	SDS	A1	3/16	13/16	1-5/16	13/16	6.2	3V506	SK	E1	1-7/16	1/8	1-7/8	19/32	8.0
5.30	4.00	3V535	SK	A1	7/32	15/16	1-7/8	7/32	8.2	3V536	SK	A1	19/32	1-5/16	1-7/8	1/4	8.9
5.60	4.31	3V565	SK	A1	7/32	15/16	1-7/8	7/32	9.1	3V566	SK	A1	19/32	1-5/16	1-7/8	1/4	9.8
6.00	4.69	3V605	SK	A1	7/32	15/16	1-7/8	7/32	10.5	3V606	SK	A1	19/32	1-5/16	1-7/8	1/4	11.2
6.50	5.25	3V655	SK	A1	7/32	15/16	1-7/8	7/32	12.1	3V656	SK	A1	19/32	1-5/16	1-7/8	1/4	12.9
6.90	5.62	3V695	SK	A1	7/32	15/16	1-7/8	7/32	13.6	3V696	SK	A1	19/32	1-5/16	1-7/8	1/4	14.5
8.00	6.63	3V805	SK	A2	7/32	15/16	1-7/8	7/32	13.6	3V806	SK	A2	5/32	7/8	1-7/8	11/16	14.7
10.60	9.25	3V1065	SK	A3	7/32	15/16	1-7/8	7/32	18.9	3V1066	SF	A3	3/16	7/8	2	17/32	22.1
14.00	12.62	3V1405	SF	A3	3/16	7/8	2	1/8	29.7	3V1406	SF	A3	3/16	7/8	2	17/32	31.9
19.00	17.62	3V1905	SF	A3	3/16	7/8	2	1/8	46.0	3V1906	E	B3	3/32	1	2-5/8	0	56.5
25.00	23.56	3V2505	E	C3	9/32	5/8	2-5/8	1/32	73.0	3V2506	E	B3	3/32	1	2-5/8	0	84.6
33.50	31.94	3V3355	E	C3	9/32	5/8	2-5/8	1/32	112.7	3V3356	E	B3	3/32	1	2-5/8	0	128.9

O.D. ◆	I.D.	Product No.	8 GROOVE							Product No.	10 GROOVE						
			F = 3-17/32								F = 4-11/32						
			Bush.	Type	E	K	L	M	Wt.		Bush.	Type	E	K	L	M	Wt.
4.75	3.88	3V4758	SK	E1	2-1/4	1/8	1-7/8	19/32	9.6	3V47510	SK	E1	3-1/16	1/8	1-7/8	19/32	9.6
5.00	3.88	3V508	SK	E1	2-1/4	1/8	1-7/8	19/32	9.3	3V5010	SK	E1	3-1/16	1/8	1-7/8	19/32	10.5
5.30	4.00	3V538	SK	A1	19/32	1-5/16	1-7/8	1-1/16	10.3	3V5310	SK	A1	23/32	1-7/16	1-7/8	1-3/4	11.6
5.60	4.31	3V568	SK	A1	19/32	1-5/16	1-7/8	1-1/16	11.3	3V5610	SK	A1	23/32	1-7/16	1-7/8	1-3/4	12.7
6.00	4.69	3V608	SK	A1	19/32	1-5/16	1-7/8	1-1/16	12.8	3V6010	SK	A1	23/32	1-7/16	1-7/8	1-3/4	14.4
6.50	5.25	3V658	SK	A1	19/32	1-5/16	1-7/8	1-1/16	14.6	3V6510	SK	A1	23/32	1-7/16	1-7/8	1-3/4	16.2
6.90	5.62	3V698	SK	A1	19/32	1-5/16	1-7/8	1-1/16	16.3	3V6910	SK	A1	23/32	1-7/16	1-7/8	1-3/4	18.1
8.00	6.68	3V808	SF	A1	7/16	1-1/8	2	1-3/32	22.0	3V8010	SF	A1	13/16	1-1/2	2	1-17/32	24.2
10.60	9.25	3V1068	SF	A3	7/16	1-1/8	2	1-3/32	25.2	3V10610	E	A2	11/32	1-1/4	2-5/8	1-3/8	40.1
14.00	12.62	3V1408	E	A3	11/32	1-1/4	2-5/8	9/16	50.3	3V14010	E	A3	11/32	1-1/4	2-5/8	1-3/8	54.7
19.00	17.62	3V1908	E	A3	11/32	1-1/4	2-5/8	9/16	68.4	3V19010	E	A3	11/32	1-1/4	2-5/8	1-3/8	77.6
25.00	23.56	3V2508	E	A3	11/32	1-1/4	2-5/8	9/16	99.3	3V25010	F	A3	1/4	1-5/16	3-5/8	15/32	126.2
33.50	31.94	3V3358	F	B3	0	1-1/16	3-5/8	3/32	154.7	3V33510	F	A3	1/4	1-5/16	3-5/8	15/32	188.4

◆ P.D. = O.D. .

Weights for all Sure-Grip bushed items are approximate and include the bushing.

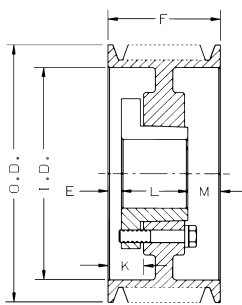

Type A

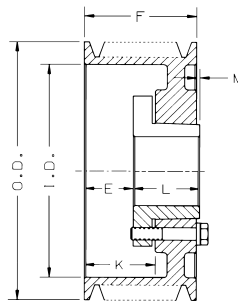

Type B

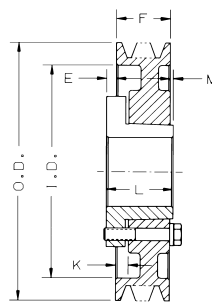

Type C

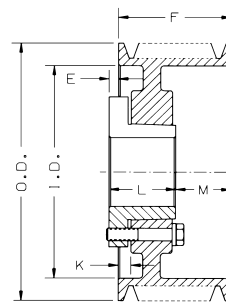

Type D

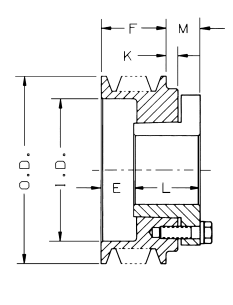

Type E

These sheaves are designed to carry the loads of all belts shown in this catalog and other similarly rated V-Belts. For special higher rated V-Belts, consult Wood's Engineering Department for recommendations.

The sheaves listed below are all stock sizes. The dimensions given are with the Sure-Grip bushings in place. When ordering, specify the bushing, if required, and the bore size. The figure following the letter in the "Type" column indicates the sheave construction: 1 – Solid, 2 – Web, 3 – Arms.

### DIMENSIONS (In Inches)

O.D. ◆	I.D.	Product No.	2 GROOVE							Product No.	3 GROOVE						
			F = 1-11/16								F = 2-3/8						
			Bush.	Type	E	K	L	M	Wt.		Bush.	Type	E	K	L	M	Wt.
4.4 †	2.72	5V442	SH	A1	1/8	11/16	1-1/4	5/16	4.0	5V443	SDS	E1	1-11/16	0	1-5/16	5/8	5.2
4.65 †	2.94	5V4652	SDS	E1	13/16	3/16	1-5/16	7/16	4.3	5V4653	SDS	E1	1-11/16	0	1-5/16	5/8	5.8
4.9 †	3.25	5V492	SDS	A1	1/16	11/16	1-5/16	5/16	4.8	5V493	SDS	A1	7/16	1-1/16	1-5/16	5/8	6.3
5.2 †	3.50	5V522	SDS	A1	1/16	11/16	1-5/16	5/16	5.4	5V523	SDS	A1	7/16	1-1/16	1-5/16	5/8	6.6
5.5 †	3.69	5V552	SDS	A1	1/16	11/16	1-5/16	5/16	6.1	5V553	SDS	A1	7/16	1-1/16	1-5/16	5/8	7.4
5.9 †	4.18	5V592	SDS	A1	1/16	11/16	1-5/16	5/16	6.8	5V593	SDS	A1	7/16	1-1/16	1-5/16	5/8	8.3
6.3 †	4.56	5V632	SK	D1	9/32	7/16	1-7/8	3/32	10.7	5V633	SK	A1	11/32	1-1/16	1-7/8	5/32	11.2
6.7 †	4.94	5V672	SK	D1	9/32	7/16	1-7/8	3/32	11.0	5V673	SK	A1	11/32	1-1/16	1-7/8	5/32	13.8
7.1	5.31	5V712	SK	D1	9/32	7/16	1-7/8	3/32	13.4	5V713	SF	A1	5/16	1	2	1/16	14.8
7.5	5.62	5V752	SK	D1	9/32	7/16	1-7/8	3/32	14.0	5V753	SF	A1	5/16	1	2	1/16	16.6
8.0	6.12	5V802	SK	D1	9/32	7/16	1-7/8	3/32	15.9	5V803	SF	A1	5/16	1	2	1/16	18.7
8.5	6.62	5V852	SK	D2	9/32	7/16	1-7/8	3/32	14.2	5V853	SF	A1	5/16	1	2	1/16	21.0
9.0	7.12	5V902	SK	D2	9/32	7/16	1-7/8	3/32	16.4	5V903	SF	A1	5/16	1	2	1/16	23.3
9.25	7.44	5V9252	SK	D2	9/32	7/16	1-7/8	3/32	16.7	5V9253	SF	A2	5/16	1	2	1/16	20.4
9.75	7.94	5V9752	SK	D3	9/32	7/16	1-7/8	3/32	14.6	5V9753	SF	A2	5/16	1	2	1/16	22.7
10.3	8.50	5V1032	SK	D3	9/32	7/16	1-7/8	3/32	16.5	5V1033	SF	A2	5/16	1	2	1/16	26.1
10.9	9.12	5V1092	SK	D3	9/32	7/16	1-7/8	3/32	17.8	5V1093	SF	A2	5/16	1	2	1/16	26.7
11.3	9.38	5V1132	SK	D3	9/32	7/16	1-7/8	3/32	18.3	5V1133	SF	A3	5/16	1	2	1/16	25.7
11.8	9.94	5V1182	SK	D3	9/32	7/16	1-7/8	3/32	19.1	5V1183	SF	A3	5/16	1	2	1/16	26.7
12.5	10.62	5V1252	SF	C3	1/4	7/16	2	1/16	21.9	5V1253	E	C3	5/32	3/4	2-5/8	3/32	35.2
13.2	11.31	5V1322	SF	C3	1/4	7/16	2	1/16	24.7	5V1323	E	C3	5/32	3/4	2-5/8	3/32	37.1
14.0	12.12	5V1402	SF	C3	1/4	7/16	2	1/16	25.9	5V1403	E	C3	5/32	3/4	2-5/8	3/32	41.0
15.0	13.12	5V1502	SF	C3	1/4	7/16	2	1/16	27.7	5V1503	E	C3	5/32	3/4	2-5/8	3/32	42.6
16.0	14.12	5V1602	SF	C3	1/4	7/16	2	1/16	30.1	5V1603	E	C3	5/32	3/4	2-5/8	3/32	45.1
18.7	16.75	5V1872	SF	C3	1/4	7/16	2	1/16	40.0	5V1873	E	C3	5/32	3/4	2-5/8	3/32	54.4
21.2	19.25	5V2122	SF	C3	1/4	7/16	2	1/16	45.0	5V2123	E	C3	5/32	3/4	2-5/8	3/32	63.0
23.6	21.62	5V2362	E	C3	5/32	3/4	2-5/8	25/32	61.7	5V2363	E	C3	5/32	3/4	2-5/8	3/32	76.0
28.0	26.00	5V2802	E	C3	5/32	3/4	2-5/8	25/32	77.5	5V2803	E	C3	5/32	3/4	2-5/8	3/32	103.6
31.5	29.50	...	...	...	...	...	...	...	...	5V3153	F	C3	1/2	9/16	3-5/8	3/4	128.4
37.5	35.25	...	...	...	...	...	...	...	...	5V3753	F	C3	1/2	9/16	3-5/8	3/4	161.9
50.0	47.38	...	...	...	...	...	...	...	...	5V5003	F	C3	1/2	9/16	3-5/8	3/4	240.0

O.D. ◆	I.D.	Product No.	4 GROOVE							Product No.	5 GROOVE						
			F = 3-1/16								F = 3-3/4						
			Bush.	Type	E	K	L	M	Wt.		Bush.	Type	E	K	L	M	Wt.
4.4 †	2.70	5V444	SD	E1	1-7/8	0	1-13/16	5/8	6.4	5V445	SD	E1	2-9/16	0	1-13/16	5/8	7.3
4.65 †	2.94	5V4654	SD	E1	1-7/8	0	1-13/16	5/8	7.1	5V4655	SD	E1	2-9/16	0	1-13/16	5/8	8.1
4.9 †	3.25	5V494	SD	A1	11/16	1-5/16	1-13/16	9/16	7.7	5V495	SD	A1	11/16	1-5/16	1-13/16	1-1/4	8.7
5.2 †	3.50	5V524	SD	A1	11/16	1-5/16	1-13/16	9/16	8.7	5V525	SD	A1	11/16	1-5/16	1-13/16	1-1/4	9.9
5.5 †	3.75	5V554	SD	A1	11/16	1-5/16	1-13/16	9/16	9.8	5V555	SD	A1	11/16	1-5/16	1-13/16	1-1/4	11.1
5.9 †	4.18	5V594	SD	A1	11/16	1-5/16	1-13/16	9/16	11.1	5V595	SK	A1	19/32	1-5/16	1-7/8	1-9/32	12.6
6.3 †	4.56	5V634	SK	A1	19/32	1-5/16	1-7/8	19/32	12.7	5V635	SK	A1	19/32	1-5/16	1-7/8	1-9/32	14.3
6.7 †	4.94	5V674	SK	A1	19/32	1-5/16	1-7/8	19/32	14.3	5V675	SF	A1	5/8	1-5/16	2	1-1/8	16.6
7.1	5.31	5V714	SF	A1	3/8	1-1/16	2	11/16	16.6	5V715	SF	A1	11/16	1-3/8	2	1-1/16	19.9
7.5	5.62	5V754	SF	A1	3/8	1-1/16	2	11/16	18.7	5V755	SF	A1	11/16	1-3/8	2	1-1/16	20.8
8.0	6.12	5V804	E	B1	17/32	1-7/16	2-5/8	3/32	25.5	5V805	E	A1	27/32	1-3/4	2-5/8	9/32	27.8
8.5	6.62	5V854	E	B1	17/32	1-7/16	2-5/8	3/32	28.4	5V855	E	A1	27/32	1-3/4	2-5/8	9/32	30.8
9.0	7.12	5V904	E	B1	17/32	1-7/16	2-5/8	3/32	31.5	5V905	E	A1	27/32	1-3/4	2-5/8	9/32	34.1
9.25	7.44	5V9254	E	B1	17/32	1-7/16	2-5/8	3/32	32.8	5V9255	E	A1	27/32	1-3/4	2-5/8	9/32	35.4
9.75	7.94	5V9754	E	B2	17/32	1-7/16	2-5/8	3/32	38.0	5V9755	E	A2	27/32	1-3/4	2-5/8	9/32	38.8
10.3	8.50	5V1034	E	B2	17/32	1-7/16	2-5/8	3/32	33.9	5V1035	E	A2	27/32	1-3/4	2-5/8	9/32	37.3
10.9	9.12	5V1094	E	B2	17/32	1-7/16	2-5/8	3/32	36.0	5V1095	E	A2	27/32	1-3/4	2-5/8	9/32	39.5
11.3	9.38	5V1134	E	B2	17/32	1-7/16	2-5/8	3/32	40.0	5V1135	E	A2	27/32	1-3/4	2-5/8	9/32	43.6
11.8	9.94	5V1184	E	B2	17/32	1-7/16	2-5/8	3/32	42.7	5V1185	E	A2	27/32	1-3/4	2-5/8	9/32	45.4
12.5	10.62	5V1254	E	B3	17/32	1-7/16	2-5/8	3/32	42.5	5V1255	E	A3	27/32	1-3/4	2-5/8	9/32	44.4
13.2	11.31	5V1324	E	B3	17/32	1-7/16	2-5/8	3/32	45.0	5V1325	E	A3	27/32	1-3/4	2-5/8	9/32	46.8
14.0	12.12	5V1404	E	B3	17/32	1-7/16	2-5/8	3/32	47.0	5V1405	E	A3	27/32	1-3/4	2-5/8	9/32	52.0
15.0	13.12	5V1504	E	B3	17/32	1-7/16	2-5/8	3/32	47.7	5V1505	E	A3	27/32	1-3/4	2-5/8	9/32	53.9
16.0	14.12	5V1604	E	B3	17/32	1-7/16	2-5/8	3/32	51.0	5V1605	E	A3	27/32	1-3/4	2-5/8	9/32	57.4
18.7	16.75	5V1874	E	A3	11/32	1-1/4	2-5/8	3/32	63.0	5V1875	F	B3	1/4	1-5/16	3-5/8	1/8	86.9
21.2	19.25	5V2124	E	A3	11/32	1-1/4	2-5/8	3/32	75.0	5V2125	F	B3	1/4	1-5/16	3-5/8	1/8	97.3
23.6	21.62	5V2364	F	B3	3/16	7/8	3-5/8	3/8	98.2	5V2365	F	B3	1/4	1-5/16	3-5/8	1/8	111.9
28.0	26.00	5V2804	F	B3	3/16	7/8	3-5/8	3/8	125.5	5V2805	F	B3	1/4	1-5/16	3-5/8	1/8	143.1
31.5	29.50	5V3154	F	C3	3/16	7/8	3-5/8	3/8	141.6	5V3155	J	C3	1/4	1	4-1/2	1/2	174.6
37.5	35.25	5V3754	F	C3	3/16	7/8	3-5/8	3/8	192.2	5V3755	J	C3	1/4	1	4-1/2	1/2	237.5
50.0	47.38	5V5004	J	C3	9/16	11/16	4-1/2	7/8	290.0	5V5005	J	C3	1/4	1	4-1/2	1/2	330.0

◆ P.D. = O.D. † Recommended for use with 5VX Narrow Cog belts only.  
Weights for all Sure-Grip bushed items are approximate and include the bushing.

# STOCK NARROW (Ultra-V) SHEAVES

# 5V



An Altra Industrial Motion Company

## DIMENSIONS (In Inches)

O.D. ◆	I.D.	Product No.	6 GROOVE F = 4-7/16							Product No.	7 GROOVE F = 5-1/8						
			Bush.	Type	E	K	L	M	Wt.		Bush.	Type	E	K	L	M	Wt.
4.4 †	2.70	5V446	SD	E1	3-1/4	0	1-13/16	5/8	8.3	...	...	...	...	...	...	...	...
4.65 †	2.94	5V4656	SD	E1	3-1/4	0	1-13/16	5/8	8.3	...	...	...	...	...	...	...	...
4.9 †	3.25	5V496	SD	A1	11/16	1-5/16	1-13/16	1-15/16	10.3	...	...	...	...	...	...	...	...
5.2 †	3.50	5V526	SD	A1	11/16	1-5/16	1-13/16	1-15/16	11.1	...	...	...	...	...	...	...	...
5.5 †	3.75	5V556	SD	A1	11/16	1-5/16	1-13/16	1-15/16	12.4	...	...	...	...	...	...	...	...
5.9 †	4.18	5V596	SK	A1	19/32	1-5/16	1-7/8	1-31/32	14.0	...	...	...	...	...	...	...	...
6.3 †	4.56	5V636	SK	A1	19/32	1-5/16	1-7/8	1-31/32	15.8	...	...	...	...	...	...	...	...
6.7 †	4.99	5V676	SF	A1	15/16	1-5/8	2	1-1/2	18.3	...	...	...	...	...	...	...	...
7.1	5.31	5V716	SF	A1	15/16	1-5/8	2	1-1/2	20.3	5V717	SF	A1	15/16	1-5/8	2	2-3/16	22.1
7.5	5.62	5V756	SF	A1	15/16	1-5/8	2	1-1/2	22.9	5V757	SF	A1	15/16	1-5/8	2	2-3/16	25.0
8.0	6.12	5V806	E	A1	1-3/32	2	2-5/8	23/32	30.1	5V807	E	A1	1-3/32	2	2-5/8	1-13/32	32.3
8.5	6.62	5V856	E	A1	1-3/32	2	2-5/8	23/32	30.3	5V857	E	A1	1-3/32	2	2-5/8	1-13/32	35.7
9.0	7.12	5V906	E	A1	1-3/32	2	2-5/8	23/32	36.7	5V907	E	A1	1-3/32	2	2-5/8	1-13/32	39.3
9.25	7.44	5V9256	E	A1	1-3/32	2	2-5/8	23/32	37.9	5V9257	E	A1	1-3/32	2	2-5/8	1-13/32	40.4
9.75	7.94	5V9756	E	A1	1-3/32	2	2-5/8	23/32	41.5	5V9757	E	A1	1-3/32	2	2-5/8	1-13/32	44.1
10.3	8.50	5V1036	E	A2	1-3/32	2	2-5/8	23/32	40.6	5V1037	F	B1	1-1/2	2-9/16	3-5/8	0	60.5
10.9	9.12	5V1096	E	A2	1-3/32	2	2-5/8	23/32	45.8	5V1097	F	B1	1-1/2	2-9/16	3-5/8	0	67.1
11.3	9.38	5V1136	E	A2	1-3/32	2	2-5/8	23/32	47.8	5V1137	F	B1	1-1/2	2-9/16	3-5/8	0	73.3
11.8	9.94	5V1186	E	A2	1-3/32	2	2-5/8	23/32	50.4	5V1187	F	B2	1-1/2	2-9/16	3-5/8	0	64.3
12.5	10.62	5V1256	F	B2	1	2-1/16	3-5/8	3/16	65.1	5V1257	F	B2	1-1/2	2-9/16	3-5/8	0	69.0
13.2	11.31	5V1326	F	B2	1	2-1/16	3-5/8	3/16	69.6	5V1327	F	B2	1-1/2	2-9/16	3-5/8	0	73.8
14.0	12.12	5V1406	F	B2	1	2-1/16	3-5/8	3/16	74.6	5V1407	F	B2	1-1/2	2-9/16	3-5/8	0	79.1
15.0	13.12	5V1506	F	B3	1	2-1/16	3-5/8	3/16	72.1	5V1507	F	B3	1-1/2	2-9/16	3-5/8	0	76.9
16.0	14.12	5V1606	F	B3	1	2-1/16	3-5/8	3/16	76.4	5V1607	F	B3	1-1/2	2-9/16	3-5/8	0	82.5
18.7	16.75	5V1876	F	A3	1/4	1-5/16	3-5/8	9/16	93.3	5V1877	F	A3	1/4	1-5/16	3-5/8	1-1/4	99.6
21.2	19.25	5V2126	F	A3	1/4	1-5/16	3-5/8	9/16	106.5	5V2127	J	A3	1/16	1-5/16	4-1/2	9/16	131.2
23.6	21.62	5V2366	J	B3	1/16	1-5/16	4-1/2	1/8	133.4	5V2367	J	A3	1/16	1-5/16	4-1/2	9/16	141.7
28.0	26.00	5V2806	J	B3	1/16	1-5/16	4-1/2	1/8	169.1	5V2807	J	A3	1/16	1-5/16	4-1/2	9/16	181.0
31.5	29.50	5V3156	J	B3	1/16	1-5/16	4-1/2	1/8	198.1	5V3157	J	A3	1/16	1-5/16	4-1/2	9/16	212.1
37.5	35.25	5V3756	J	B3	1/16	1-5/16	4-1/2	1/8	253.8	5V3757	M	B3	15/32	1-15/16	6-3/4	2-3/32	349.6
50.0	47.38	5V5006	M	C3	31/32	1/2	6-3/4	1-11/32	472.1	5V5007	M	C3	31/32	1/2	6-3/4	21/32	498.1

◆ P.D. = O.D. † Recommended for use with 5VX Narrow Cog belts only.  
Weights for all Sure-Grip bushed items are approximate and include the bushing.

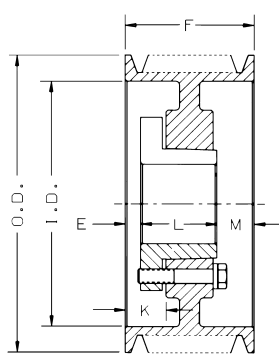

Type A

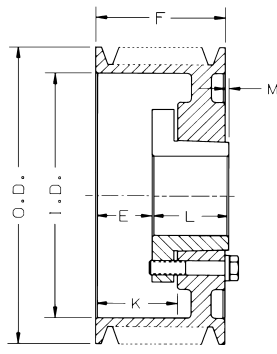

Type B

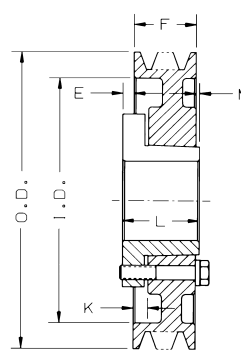

Type C

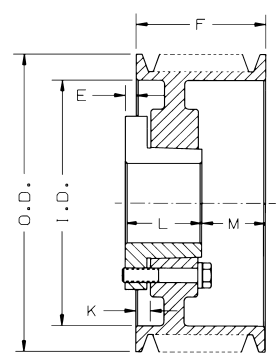

Type D

## DIMENSIONS (In Inches)

O.D. ◆	I.D.	Product No.	8 GROOVE						Product No.	9 GROOVE							
			F = 5-13/16							F = 6-1/2							
			Bush.	Type	E	K	L	M		Wt.	Bush.	Type	E	K	L	M	Wt.
7.1	5.31	5V718	SF	A1	1-7/16	2-1/8	2	2-3/8	24.0	...	...	...	...	...	...	...	...
7.5	5.62	5V758	SF	A1	1-7/16	2-1/8	2	2-3/8	27.1	...	...	...	...	...	...	...	...
8.0	6.12	5V808	E	A1	1-19/32	2-1/2	2-5/8	1-19/32	34.6	5V809	E	A1	1-19/32	2-1/2	2-5/8	2-9/32	36.9
8.5	6.62	5V858	E	A1	1-19/32	2-1/2	2-5/8	1-19/32	38.2	5V859	E	A1	1-19/32	2-1/2	2-5/8	2-9/32	40.6
9.0	7.12	5V908	E	A1	1-19/32	2-1/2	2-5/8	1-19/32	41.9	5V909	E	A1	1-19/32	2-1/2	2-5/8	2-9/32	44.5
9.25	7.44	5V9258	F	A1	1-1/2	2-9/16	3-5/8	11/16	51.7	5V9259	F	A1	1-1/2	2-9/16	3-5/8	1-3/8	54.2
9.75	7.94	5V9758	F	A1	1-1/2	2-9/16	3-5/8	11/16	57.0	5V9759	F	A1	1-1/2	2-9/16	3-5/8	1-3/8	59.7
10.3	8.50	5V1038	F	A1	1-1/2	2-9/16	3-5/8	11/16	63.4	5V1039	F	A1	1-1/2	2-9/16	3-5/8	1-3/8	66.3
10.9	9.12	5V1098	F	A1	1-1/2	2-9/16	3-5/8	11/16	70.2	5V1099	F	A1	1-1/2	2-9/16	3-5/8	1-3/8	73.3
11.3	9.38	5V1138	F	A1	1-1/2	2-9/16	3-5/8	11/16	76.9	5V1139	F	A1	1-1/2	2-9/16	3-5/8	1-3/8	80.5
11.8	9.94	5V1188	F	A2	1-1/2	2-9/16	3-5/8	11/16	67.9	5V1189	F	A2	1-1/2	2-9/16	3-5/8	1-3/8	71.4
12.5	10.62	5V1258	F	A2	1-1/2	2-9/16	3-5/8	11/16	72.8	5V1259	F	A2	1-1/2	2-9/16	3-5/8	1-3/8	76.8
13.2	11.31	5V1328	F	A2	1-1/2	2-9/16	3-5/8	11/16	77.9	5V1329	F	A2	1-1/2	2-9/16	3-5/8	1-3/8	83.9
14.0	12.12	5V1408	F	A2	1-1/2	2-9/16	3-5/8	11/16	83.3	5V1409	F	A2	1-1/2	2-9/16	3-5/8	1-3/8	90.2
15.0	13.12	5V1508	F	A3	1-1/2	2-9/16	3-5/8	11/16	81.5	5V1509	J	B2	2-5/16	3-9/16	4-1/2	5/16	109.5
16.0	14.12	5V1608	F	A3	1-1/2	2-9/16	3-5/8	11/16	87.4	5V1609	J	B3	2-5/16	3-9/16	4-1/2	5/16	109.0
18.7	16.75	5V1878	J	A3	5/16	1-9/16	4-1/2	1	124.6	5V1879	J	A3	5/16	1-9/16	4-1/2	1-11/16	128.6
21.2	19.25	5V2128	J	A3	5/16	1-9/16	4-1/2	1	138.9	5V2129	J	A3	5/16	1-9/16	4-1/2	1-11/16	146.0
23.6	21.62	5V2368	J	A3	5/16	1-9/16	4-1/2	1	154.6	5V2369	J	A3	5/16	1-9/16	4-1/2	1-11/16	165.1
28.0	26.00	5V2808	J	A3	5/16	1-9/16	4-1/2	1	191.0	5V2809	M	B3	15/32	1-15/16	6-3/4	23/32	273.7
31.5	29.50	5V3158	M	B3	15/32	1-15/16	6-3/4	1-13/32	295.7	5V3159	M	B3	15/32	1-15/16	6-3/4	23/32	316.0
37.5	35.25	5V3758	M	B3	15/32	1-15/16	6-3/4	1-13/32	366.2	5V3759	M	B3	15/32	1-15/16	6-3/4	23/32	398.5
50.0	47.38	5V5008	M	B3	15/32	1-15/16	6-3/4	1-13/32	540.0	5V5009	M	B3	15/32	1-15/16	6-3/4	23/32	580.1

O.D. ◆	I.D.	Product No.	10 GROOVE						
			F = 7-3/16						
			Bush.	Type	E	K	L	M	Wt.
8.0	6.12	5V8010	E	A1	2-11/32	3-1/4	2-5/8	2-7/32	39.1
8.5	6.62	5V8510	E	A1	2-11/32	3-1/4	2-5/8	2-7/32	43.0
9.0	7.12	5V9010	F	A1	2-1/4	3-5/16	3-5/8	1-5/16	54.9
9.25	7.38	5V92510	F	A1	2-1/4	3-5/16	3-5/8	1-5/16	59.1
9.75	7.94	5V97510	F	A1	2-1/4	3-5/16	3-5/8	1-5/16	62.4
10.3	8.50	5V10310	F	A1	2-1/4	3-5/16	3-5/8	1-5/16	69.2
10.9	9.12	5V10910	F	A1	2-1/4	3-5/16	3-5/8	1-5/16	76.3
11.3	9.38	5V11310	F	A1	2-1/4	3-5/16	3-5/8	1-5/16	84.0
11.8	9.94	5V11810	F	A2	2-1/4	3-5/16	3-5/8	1-5/16	75.0
12.5	10.62	5V12510	J	A2	2-5/16	3-9/16	4-1/2	3/8	92.9
13.2	11.31	5V13210	J	A2	2-5/16	3-9/16	4-1/2	3/8	99.0
14.0	12.12	5V14010	J	A2	2-5/16	3-9/16	4-1/2	3/8	105.4
15.0	13.12	5V15010	J	A2	2-5/16	3-9/16	4-1/2	3/8	99.0
16.0	14.12	5V16010	J	A3	2-5/16	3-9/16	4-1/2	3/8	114.1
18.7	16.75	5V18710	J	A3	5/16	1-9/16	4-1/2	2-3/8	136.4
21.2	19.25	5V21210	J	A3	5/16	1-9/16	4-1/2	2-3/8	159.4
23.6	21.62	5V23610	M	B3	15/32	1-15/16	6-3/4	1/32	245.8
28.0	26.00	5V28010	M	B3	15/32	1-15/16	6-3/4	1/32	293.0
31.5	29.50	5V31510	M	B3	15/32	1-15/16	6-3/4	1/32	329.1
37.5	35.25	5V37510	M	B3	15/32	1-15/16	6-3/4	1/32	421.0
50.0	47.38	5V50010	M	B3	15/32	1-15/16	6-3/4	1/32	637.1

◆ P.D. = O.D.

Weights for all Sure-Grip bushed items are approximate and include the bushing.

# STOCK NARROW (Ultra-V) SHEAVES

# 8V

# TB Wood's Incorporated

An Altra Industrial Motion Company

These sheaves are designed to carry the loads of all belts shown in this catalog and other similarly rated V-Belts. For special higher rated V-Belts, consult Wood's Engineering Department for recommendations.

The sheaves listed below are all stock sizes. The dimensions given are with the Sure-Grip bushings in place. When ordering, specify the bushing, if required, and the bore size. The figure following the letter in the "Type" column indicates the sheave construction: 1 – Solid, 2 – Web, 3 – Arms.

## DIMENSIONS (In Inches)

O.D. ◆	I.D.	Product No.	4 GROOVE							Product No.	5 GROOVE						
			F = 4-7/8								F = 6						
			Bush.	Type	E	K	L	M	Wt.		Bush.	Type	E	K	L	M	Wt.
12.5	9.75	8V1254	F	A1	1/8	1-3/16	3-5/8	1-1/8	85.5	8V1255	F	A1	1-1/4	2-5/16	3-5/8	1-1/8	93.3
13.2	10.44	8V1324	F	A2	1/8	1-3/16	3-5/8	1-1/8	78.4	8V1325	F	A2	1-1/4	2-5/16	3-5/8	1-1/8	88.2
14.0	11.25	8V1404	F	A2	1/8	1-3/16	3-5/8	1-1/8	84.5	8V1405	F	A2	1-1/4	2-5/16	3-5/8	1-1/8	95.2
15.0	12.25	8V1504	F	A2	1/8	1-3/16	3-5/8	1-1/8	92.6	8V1505	F	A2	1-1/4	2-5/16	3-5/8	1-1/8	108.0
16.0	13.25	8V1604	F	A2	1/8	1-3/16	3-5/8	1-1/8	98.8	8V1605	F	A2	1-1/4	2-5/16	3-5/8	1-1/8	112.1
17.0	14.25	8V1704	F	A2	1/8	1-3/16	3-5/8	1-1/8	109.4	8V1705	J	A2	3/4	2	4-1/2	3/4	141.0
18.0	15.25	8V1804	F	A2	1/8	1-3/16	3-5/8	1-1/8	118.1	8V1805	J	A2	3/4	2	4-1/2	3/4	157.0
19.0	16.25	8V1904	F	A2	1/8	1-3/16	3-5/8	1-1/8	128.3	8V1905	J	A2	3/4	2	4-1/2	3/4	169.0
20.0	17.25	8V2004	J	A3	3/16	1-7/16	4-1/2	3/16	128.3	8V2005	J	A2	3/4	2	4-1/2	3/4	167.5
21.2	18.44	8V2124	J	A3	3/16	1-7/16	4-1/2	3/16	142.8	8V2125	J	A2	3/4	2	4-1/2	3/4	183.8
22.4	19.62	8V2244	J	A3	3/16	1-7/16	4-1/2	3/16	154.2	8V2245	M	B2	15/32	1-15/16	6-3/4	1-7/32	262.0
24.8	21.90	8V2484	M	C3	21/32	13/16	6-3/4	1-7/32	247.5	8V2485	M	B3	15/32	1-15/16	6-3/4	1-7/32	266.5
30.0	27.12	8V3004	M	C3	21/32	13/16	6-3/4	1-7/32	286.7	8V3005	M	B3	15/32	1-15/16	6-3/4	1-7/32	327.6
35.5	32.50	8V3554	M	C3	21/32	13/16	6-3/4	1-7/32	342.0	8V3555	M	B3	15/32	1-15/16	6-3/4	1-7/32	404.0
40.0	37.00	8V4004	M	C3	21/32	13/16	6-3/4	1-7/32	407.6	8V4005	M	B3	15/32	1-15/16	6-3/4	1-7/32	441.0
44.5	41.60	8V4454	M	C3	21/32	13/16	6-3/4	1-7/32	461.0	8V4455	N	C3	3/4	15/16	8-1/8	1-3/8	580.5
53.0	49.81	8V5304	M	C3	21/32	13/16	6-3/4	1-7/32	557.0	8V5305	N	C3	3/4	15/16	8-1/8	1-3/8	688.0

◆ P.D. = O.D.

Weights for all Sure-Grip bushed items are approximate and include the bushing.

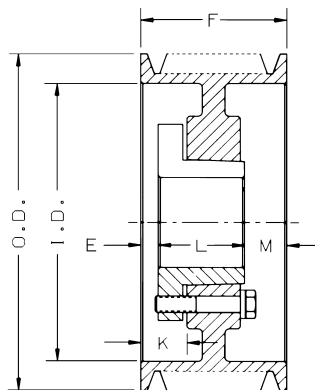

Type A

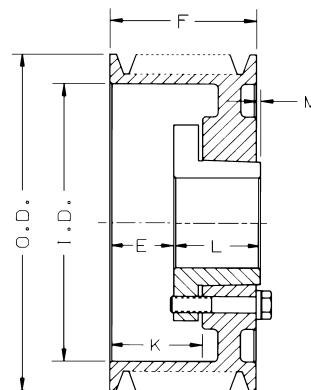

Type B

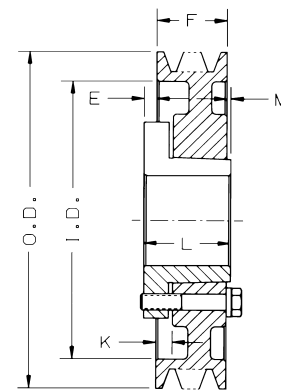

Type C

## DIMENSIONS (In Inches)

O.D. ◆	I.D.	Product No.	6 GROOVE							Product No.	8 GROOVE						
			F = 7-1/8								F = 9-3/8						
			Bush.	Type	E	K	L	M	Wt.		Bush.	Type	E	K	L	M	Wt.
12.5	9.75	8V1256	F	A1	1-1/4	2-5/16	3-5/8	2-1/4	100.9	8V1258	J	A1	2-5/16	3-9/16	4-1/2	2-9/16	129.1
13.2	10.44	8V1326	F	A2	1-1/4	2-5/16	3-5/8	2-1/4	96.6	8V1328	J	A1	2-5/16	3-9/16	4-1/2	2-9/16	144.5
14.0	11.25	8V1406	F	A2	1-1/4	2-5/16	3-5/8	2-1/4	104.1	8V1408	J	A2	2-5/16	3-9/16	4-1/2	2-9/16	136.6
15.0	12.25	8V1506	J	A2	1-5/16	2-9/16	4-1/2	1-5/16	133.0	8V1508	J	A2	2-5/16	3-9/16	4-1/2	2-9/16	146.5
16.0	13.25	8V1606	J	A2	1-5/16	2-9/16	4-1/2	1-5/16	143.5	8V1608	J	A2	2-5/16	3-9/16	4-1/2	2-9/16	164.5
17.0	14.25	8V1706	J	A2	1-5/16	2-9/16	4-1/2	1-5/16	153.0	8V1708	M	A2	2-15/32	3-15/16	6-3/4	5/32	244.1
18.0	15.25	8V1806	J	A2	1-5/16	2-9/16	4-1/2	1-5/16	169.0	8V1808	M	A2	2-15/32	3-15/16	6-3/4	5/32	257.0
19.0	16.25	8V1906	J	A2	1-5/16	2-9/16	4-1/2	1-5/16	182.0	8V1908	M	A2	2-15/32	3-15/16	6-3/4	5/32	280.0
20.0	17.25	8V2006	M	B2	1-15/32	2-15/16	6-3/4	1-3/32	242.8	8V2008	M	A2	2-15/32	3-15/16	6-3/4	5/32	292.6
21.2	18.44	8V2126	M	B2	1-15/32	2-15/16	6-3/4	1-3/32	263.3	8V2128	M	A2	2-15/32	3-15/16	6-3/4	5/32	314.0
22.4	19.62	8V2246	M	B2	1-15/32	2-15/16	6-3/4	1-3/32	280.9	8V2248	M	A2	2-15/32	3-15/16	6-3/4	5/32	338.0
24.8	21.90	8V2486	M	B3	15/32	1-15/16	6-3/4	3/32	285.5	8V2488	N	A3	9/16	2-1/4	8-1/8	11/16	377.0
30.0	27.12	8V3006	M	B3	15/32	1-15/16	6-3/4	3/32	354.4	8V3008	N	A3	9/16	2-1/4	8-1/8	11/16	468.9
35.5	32.50	8V3556	N	C3	9/16	1-1/8	8-1/8	7/16	537.0	8V3558	N	A3	9/16	2-1/4	8-1/8	11/16	588.0
40.0	37.00	8V4006	N	C3	9/16	1-1/8	8-1/8	7/16	549.9	8V4008	N	A3	9/16	2-1/4	8-1/8	11/16	663.0
44.5	41.60	8V4456	N	C3	9/16	1-1/8	8-1/8	7/16	619.5	8V4458	P	B3	3/4	2-5/8	9-3/8	3/4	860.0
53.0	49.81	8V5306	N	C3	9/16	1-1/8	8-1/8	7/16	768.0	8V5308	P	B3	3/4	2-5/8	9-3/8	3/4	992.0
63.0	59.69	8V6306	P	B3	1/8	2	9-3/8	2-3/8	1027.0	8V6308	P	B3	3/4	2-5/8	9-3/8	3/4	1262.0
71.0	67.70	8V7106	P	B3	1/8	2	9-3/8	2-3/8	1200.0	8V7108	W	B3	0	2-1/4	11-3/8	2	1725.0

O.D. ◆	I.D.	Product No.	10 GROOVE							Product No.	12 GROOVE						
			F = 11-5/8								F = 13-7/8						
			Bush.	Type	E	K	L	M	Wt.		Bush.	Type	E	K	L	M	Wt.
12.5	9.75	8V12510	J	A1	2-5/16	3-9/16	4-1/2	4-13/16	148.9	8V12512	M	A1	2-15/32	3-15/16	6-3/4	4-21/32	198.0
13.2	10.44	8V13210	J	A1	2-5/16	3-9/16	4-1/2	4-13/16	148.6	8V13212	M	A1	2-15/32	3-15/16	6-3/4	4-21/32	225.0
14.0	11.25	8V14010	J	A1	2-5/16	3-9/16	4-1/2	4-13/16	161.0	8V14012	M	A1	2-15/32	3-15/16	6-3/4	4-21/32	245.8
15.0	12.25	8V15010	M	A1	2-15/32	3-15/16	6-3/4	2-13/32	264.0	8V15012	M	A1	2-15/32	3-15/16	6-3/4	4-21/32	285.0
16.0	13.25	8V16010	M	A1	2-15/32	3-15/16	6-3/4	2-13/32	296.7	8V16012	M	A1	2-15/32	3-15/16	6-3/4	4-21/32	324.0
17.0	14.25	8V17010	M	A2	2-15/32	3-15/16	6-3/4	2-13/32	269.1	8V17012	M	A2	2-15/32	3-15/16	6-3/4	4-21/32	324.0
18.0	15.25	8V18010	M	A2	2-15/32	3-15/16	6-3/4	2-13/32	295.0	8V18012	M	A2	2-15/32	3-15/16	6-3/4	4-21/32	338.0
19.0	16.25	8V19010	M	A2	2-15/32	3-15/16	6-3/4	2-13/32	318.0	8V19012	N	A2	9/16	2-1/4	8-1/8	5-3/16	412.0
20.0	17.25	8V20010	M	A2	2-15/32	3-15/16	6-3/4	2-13/32	318.6	8V20012	N	A2	9/16	2-1/4	8-1/8	5-3/16	411.0
21.2	18.44	8V21210	M	A2	2-15/32	3-15/16	6-3/4	2-13/32	340.7	8V21212	N	A2	9/16	2-1/4	8-1/8	5-3/16	421.0
22.4	19.62	8V22410	N	A2	9/16	2-1/4	8-1/8	2-15/16	411.1	8V22412	N	A2	9/16	2-1/4	8-1/8	5-3/16	478.0
24.8	21.90	8V24810	N	A2	9/16	2-1/4	8-1/8	2-15/16	463.0	8V24812	N	A2	9/16	2-1/4	8-1/8	5-3/16	516.5
30.0	27.12	8V30010	N	A3	9/16	2-1/4	8-1/8	2-15/16	557.5	8V30012	P	A3	3/4	2-5/8	9-3/8	3-3/4	672.1
35.5	32.50	8V35510	P	A3	3/4	2-5/8	9-3/8	1-1/2	727.0	8V35512	P	A3	3/4	2-5/8	9-3/8	3-3/4	837.0
40.0	37.00	8V40010	P	A3	3/4	2-5/8	9-3/8	1-1/2	817.9	8V40012	P	A3	3/4	2-5/8	9-3/8	3-3/4	909.5
44.5	41.60	8V44510	P	A3	3/4	2-5/8	9-3/8	1-1/2	927.0	8V44512	P	A3	3/4	2-5/8	9-3/8	3-3/4	1097.0
53.0	49.81	8V53010	P	A3	3/4	2-5/8	9-3/8	1-1/2	1137.0	8V53012	W	A3	5/8	2-7/8	11-3/8	1-7/8	1482.0
63.0	59.69	8V63010	W	B3	3/8	2-5/8	11-3/8	1/8	1652.0	8V63012	W	A3	5/8	2-7/8	11-3/8	1-7/8	1777.0
71.0	67.70	8V71010	W	B3	3/8	2-5/8	11-3/8	1/8	1865.0	8V71012	W	A3	5/8	2-7/8	11-3/8	1-7/8	2180.0

◆ P.D. = O.D.

Weights for all Sure-Grip bushed items are approximate and include the bushing.

# NARROW (Premium-V) V-BELT FEATURES

**Narrow Premium-V belts** have the highest power density of any v-belt, and stretch dramatically less than standard cross sections. That's why they're ideal for use on problem drives requiring high-impact strength and load-carrying power. Wood's **Narrow premium V-belts** have the same cross section dimensions as the corresponding Wood's Narrow Ultra-V belts and they meet RMA oil and heat resistance standards.

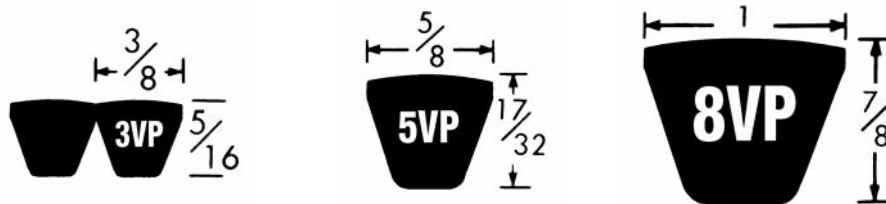

## All Premium-V Belts are constructed with :

### Kevlar\* or aramid tensile cords

Give extraordinary strength, durability and virtually zero stretch

### Specially-treated extra tough cover

Withstands slip and shear forces at peak loads without generating excessive heat; fends off penetration by foreign materials

### Heavy duty double fabric cover

Creates maximum abrasion resistance that protects against wear caused by fine airborne dust in rock quarries and lumber mills, which can cause rapid belt sidewall wear resulting in early failures

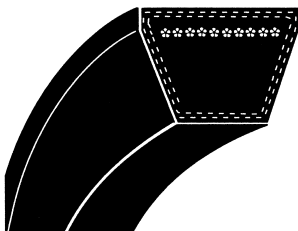

### Narrow (Premium-V) Single V-belts

For applications when Banded belts are not an option. Single belts are specially designed for use on deep groove sheaves and drives with limited room for "take up."

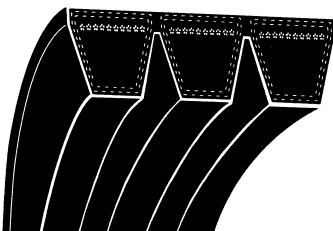

**Narrow (Premium-V) Banded V-belts** Replaces several belts with the strength of a single belt. Banded belts feature a multiple layer band that provide excellent lateral rigidity to prevent belts from turning over from coming off of the drive.

**Warning: When incorporating TB Wood's Premium-V belts, it is important to evaluate the load capacity of Ultra-V sheaves. The exceptional strength of Premium-V belts, combined with tough application environments, may require extra heavy-duty sheaves that can meet the challenge. TB Wood's can design and manufacture a full array of sheaves to meet the specific needs of your application.**

\*Kevlar® is a registered trademark of Dupont™

## 5VP Single Belts

Product No.	Belt Length	Wt. Lbs.	Product No.	Belt Length	Wt. Lbs.
5VP800	80.0	1.02	5VP1800	180.0	2.30
5VP850	85.0	1.08	5VP1900	190.0	2.42
5VP900	90.0	1.15	5VP2000	200.0	2.55
5VP950	95.0	1.21	5VP2120	212.0	2.70
5VP1000	100.0	1.28	5VP2240	224.0	2.86
5VP1060	106.0	1.35	5VP2360	236.0	3.01
5VP1120	112.0	1.43	5VP2500	250.0	3.19
5VP1180	118.0	1.50	5VP2650	265.0	3.38
5VP1250	125.0	1.59	5VP2800	280.0	3.57
5VP1320	132.0	1.68	5VP3000	300.0	3.83
5VP1400	140.0	1.79	5VP3150	315.0	4.02
5VP1500	150.0	1.91	5VP3350	335.0	4.27
5VP1600	160.0	2.04	5VP3550	355.0	4.53
5VP1700	170.0	2.17			

## 8VP Single Belts

Product No.	Belt Length	Wt. Lbs.	Product No.	Belt Length	Wt. Lbs.
8VP1600	160.0	5.29	8VP2500	250.0	8.26
8VP1700	170.0	5.62	8VP2650	265.0	8.75
8VP1800	180.0	5.95	8VP2800	280.0	9.25
8VP1900	190.0	6.28	8VP3000	300.0	9.91
8VP2000	200.0	6.61	8VP3150	315.0	10.41
8VP2120	212.0	7.00	8VP3350	335.0	11.07
8VP2240	224.0	7.40	8VP3550	355.0	11.73
8VP2360	236.0	7.80			

## 3VP Narrow (Premium-V) Banded Belts

Product No.	Belt Length	Wt. Lbs.	Product No.	Belt Length	Wt. Lbs.	Product No.	Belt Length	Wt. Lbs.	Product No.	Belt Length	Wt. Lbs.
2/3VP450	45	0.51	2/3VP630	63	0.72	2/3VP900	90	1.03	2/3VP1250	125	1.43
3/3VP450	45	0.77	3/3VP630	63	1.08	3/3VP900	90	1.54	3/3VP1250	125	2.14
4/3VP450	45	1.03	4/3VP630	63	1.44	4/3VP900	90	2.06	4/3VP1250	125	2.86
5/3VP450	45	1.29	5/3VP630	63	1.80	5/3VP900	90	2.57	5/3VP1250	125	3.57
2/3VP475	47.5	0.54	2/3VP670	67	0.77	2/3VP950	95	1.09	2/3VP1320	132	1.51
3/3VP475	47.5	0.81	3/3VP670	67	1.15	3/3VP950	95	1.63	3/3VP1320	132	2.26
4/3VP475	47.5	1.09	4/3VP670	67	1.53	4/3VP950	95	2.17	4/3VP1320	132	3.02
5/3VP475	47.5	1.36	5/3VP670	67	1.91	5/3VP950	95	2.71	5/3VP1320	132	3.77
2/3VP500	50	0.57	2/3VP710	71	0.81	2/3VP1000	100	1.14	2/3VP1400	140	1.60
3/3VP500	50	0.86	3/3VP710	71	1.22	3/3VP1000	100	1.71	3/3VP1400	140	2.40
4/3VP500	50	1.14	4/3VP710	71	1.62	4/3VP1000	100	2.28	4/3VP1400	140	3.20
5/3VP500	50	1.43	5/3VP710	71	2.03	5/3VP1000	100	2.86	5/3VP1400	140	4.00
2/3VP530	53	0.61	2/3VP750	75	0.86	2/3VP1060	106	1.21			
3/3VP530	53	0.91	3/3VP750	75	1.29	3/3VP1060	106	1.82			
4/3VP530	53	1.21	4/3VP750	75	1.71	4/3VP1060	106	2.42			
5/3VP530	53	1.51	5/3VP750	75	2.14	5/3VP1060	106	3.03			
2/3VP560	56	0.64	2/3VP800	80	0.91	2/3VP1120	112	1.28			
3/3VP560	56	0.96	3/3VP800	80	1.37	3/3VP1120	112	1.92			
4/3VP560	56	1.28	4/3VP800	80	1.83	4/3VP1120	112	2.56			
5/3VP560	56	1.60	5/3VP800	80	2.28	5/3VP1120	112	3.20			
2/3VP600	60	0.69	2/3VP850	85	0.97	2/3VP1180	118	1.35			
3/3VP600	60	1.03	3/3VP850	85	1.46	3/3VP1180	118	2.02			
4/3VP600	60	1.37	4/3VP850	85	1.94	4/3VP1180	118	2.70			
5/3VP600	60	1.71	5/3VP850	85	2.43	5/3VP1180	118	3.37			

Available up to 10 strands. 6-10 strands made to order.



# NARROW (Premium-V) BANDED V-BELTS



An Altra Industrial Motion Company

## 5VP Narrow (Premium-V) Banded Belts

Product No.	Belt Length	Wt. Lbs.	Product No.	Belt Length	Wt. Lbs.	Product No.	Belt Length	Wt. Lbs.	Product No.	Belt Length	Wt. Lbs.
2/5VP600	60	1.69	2/5VP950	95	2.68	2/5VP1600	160	4.52	2/5VP2500	250	7.06
3/5VP600	60	2.54	3/5VP950	95	4.02	3/5VP1600	160	6.77	3/5VP2500	250	10.58
4/5VP600	60	3.39	4/5VP950	95	5.36	4/5VP1600	160	9.03	4/5VP2500	250	14.11
5/5VP600	60	4.23	5/5VP950	95	6.70	5/5VP1600	160	11.29	5/5VP2500	250	17.64
2/5VP630	63	1.78	2/5VP1000	100	2.82	2/5VP1700	170	4.80	2/5VP2650	265	7.48
3/5VP630	63	2.67	3/5VP1000	100	4.23	3/5VP1700	170	7.20	3/5VP2650	265	11.22
4/5VP630	63	3.56	4/5VP1000	100	5.64	4/5VP1700	170	9.60	4/5VP2650	265	14.96
5/5VP630	63	4.45	5/5VP1000	100	7.06	5/5VP1700	170	11.99	5/5VP2650	265	18.70
2/5VP670	67	1.89	2/5VP1060	106	2.99	2/5VP1800	180	5.08	2/5VP2800	280	7.90
3/5VP670	67	2.84	3/5VP1060	106	4.49	3/5VP1800	180	7.62	3/5VP2800	280	11.85
4/5VP670	67	3.78	4/5VP1060	106	5.98	4/5VP1800	180	10.16	4/5VP2800	280	15.80
5/5VP670	67	4.73	5/5VP1060	106	7.48	5/5VP1800	180	12.70	5/5VP2800	280	19.76
2/5VP710	71	2.00	2/5VP1120	112	3.16	2/5VP1900	190	5.36	2/5VP3000	300	8.47
3/5VP710	71	3.01	3/5VP1120	112	4.74	3/5VP1900	190	8.04	3/5VP3000	300	12.70
4/5VP710	71	4.01	4/5VP1120	112	6.32	4/5VP1900	190	10.72	4/5VP3000	300	16.93
5/5VP710	71	5.01	5/5VP1120	112	7.90	5/5VP1900	190	13.41	5/5VP3000	300	21.17
2/5VP750	75	2.12	2/5VP1180	118	3.33	2/5VP2000	200	5.64	2/5VP3150	315	8.89
3/5VP750	75	3.18	3/5VP1180	118	5.00	3/5VP2000	200	8.47	3/5VP3150	315	13.34
4/5VP750	75	4.23	4/5VP1180	118	6.66	4/5VP2000	200	11.29	4/5VP3150	315	17.78
5/5VP750	75	5.29	5/5VP1180	118	8.33	5/5VP2000	200	14.11	5/5VP3150	315	22.23
2/5VP800	80	2.26	2/5VP1250	125	3.53	2/5VP2030	203	5.73	2/5VP3350	335	9.45
3/5VP800	80	3.39	3/5VP1250	125	5.29	3/5VP2030	203	8.59	3/5VP3350	335	14.18
4/5VP800	80	4.52	4/5VP1250	125	7.06	4/5VP2030	203	11.46	4/5VP3350	335	18.91
5/5VP800	80	5.64	5/5VP1250	125	8.82	5/5VP2030	203	14.32	5/5VP3350	335	23.64
2/5VP850	85	2.40	2/5VP1320	132	3.73	2/5VP2120	212	5.98	2/5VP3550	355	10.02
3/5VP850	85	3.60	3/5VP1320	132	5.59	3/5VP2120	212	8.97	3/5VP3550	355	15.03
4/5VP850	85	4.80	4/5VP1320	132	7.45	4/5VP2120	212	11.97	4/5VP3550	355	20.04
5/5VP850	85	6.00	5/5VP1320	132	9.31	5/5VP2120	212	14.96	5/5VP3550	355	25.05
2/5VP870	87	2.46	2/5VP1400	140	3.95	2/5VP2240	224	6.32			
3/5VP870	87	3.68	3/5VP1400	140	5.93	3/5VP2240	224	9.48			
4/5VP870	87	4.91	4/5VP1400	140	7.90	4/5VP2240	224	12.64			
5/5VP870	87	6.14	5/5VP1400	140	9.88	5/5VP2240	224	15.80			
2/5VP900	90	2.54	2/5VP1500	150	4.23	2/5VP2360	236	6.66			
3/5VP900	90	3.81	3/5VP1500	150	6.35	3/5VP2360	236	9.99			
4/5VP900	90	5.08	4/5VP1500	150	8.47	4/5VP2360	236	13.32			
5/5VP900	90	6.35	5/5VP1500	150	10.58	5/5VP2360	236	16.65			

Available up to 16 strands. 6-16 strands made to order.

**8VP Narrow (Premium-V) Banded Belts**

Product No.	Belt Length	Wt. Lbs.	Product No.	Belt Length	Wt. Lbs.	Product No.	Belt Length	Wt. Lbs.	Product No.	Belt Length	Wt. Lbs.
2/8VP1000	100	6.95	2/8VP1600	160	11.13	2/8VP2500	250	17.39	2/8VP4000	400	27.82
3/8VP1000	100	10.43	3/8VP1600	160	16.69	3/8VP2500	250	26.08	3/8VP4000	400	41.73
4/8VP1000	100	13.91	4/8VP1600	160	22.26	4/8VP2500	250	34.77	4/8VP4000	400	55.64
5/8VP1000	100	17.39	5/8VP1600	160	27.82	5/8VP2500	250	43.47	5/8VP4000	400	69.55
2/8VP1060	106	7.37	2/8VP1700	170	11.82	2/8VP2650	265	18.43	2/8VP4250	425	29.56
3/8VP1060	106	11.06	3/8VP1700	170	17.73	3/8VP2650	265	27.65	3/8VP4250	425	44.34
4/8VP1060	106	14.74	4/8VP1700	170	23.65	4/8VP2650	265	36.86	4/8VP4250	425	59.12
5/8VP1060	106	18.43	5/8VP1700	170	29.56	5/8VP2650	265	46.08	5/8VP4250	425	73.89
2/8VP1120	112	7.79	2/8VP1800	180	12.52	2/8VP2800	280	19.47	2/8VP4500	450	31.30
3/8VP1120	112	11.68	3/8VP1800	180	18.78	3/8VP2800	280	29.21	3/8VP4500	450	46.95
4/8VP1120	112	15.58	4/8VP1800	180	25.04	4/8VP2800	280	38.95	4/8VP4500	450	62.59
5/8VP1120	112	19.47	5/8VP1800	180	31.30	5/8VP2800	280	48.68	5/8VP4500	450	78.24
2/8VP1180	118	8.21	2/8VP1900	190	13.21	2/8VP3000	300	20.86	2/8VP4750	475	33.04
3/8VP1180	118	12.31	3/8VP1900	190	19.82	3/8VP3000	300	31.30	3/8VP4750	475	49.55
4/8VP1180	118	16.41	4/8VP1900	190	26.43	4/8VP3000	300	41.73	4/8VP4750	475	66.07
5/8VP1180	118	20.52	5/8VP1900	190	33.04	5/8VP3000	300	52.16	5/8VP4750	475	82.59
2/8VP1250	125	8.69	2/8VP2000	200	13.91	2/8VP3150	315	21.91	2/8VP5000	500	34.77
3/8VP1250	125	13.04	3/8VP2000	200	20.86	3/8VP3150	315	32.86	3/8VP5000	500	52.16
4/8VP1250	125	17.39	4/8VP2000	200	27.82	4/8VP3150	315	43.82	4/8VP5000	500	69.55
5/8VP1250	125	21.73	5/8VP2000	200	34.77	5/8VP3150	315	54.77	5/8VP5000	500	86.94
2/8VP1320	132	9.18	2/8VP2120	212	14.74	2/8VP3350	335	23.30	2/8VP5600	560	38.95
3/8VP1320	132	13.77	3/8VP2120	212	22.12	3/8VP3350	335	34.95	3/8VP5600	560	58.42
4/8VP1320	132	18.36	4/8VP2120	212	29.49	4/8VP3350	335	46.60	4/8VP5600	560	77.89
5/8VP1320	132	22.95	5/8VP2120	212	36.86	5/8VP3350	335	58.25	5/8VP5600	560	97.37
2/8VP1400	140	9.74	2/8VP2240	224	15.58	2/8VP3550	355	24.69	2/8VP6000	600	41.73
3/8VP1400	140	14.61	3/8VP2240	224	23.37	3/8VP3550	355	37.03	3/8VP6000	600	62.59
4/8VP1400	140	19.47	4/8VP2240	224	31.16	4/8VP3550	355	49.38	4/8VP6000	600	83.46
5/8VP1400	140	24.34	5/8VP2240	224	38.95	5/8VP3550	355	61.72	5/8VP6000	600	104.32
2/8VP1500	150	10.43	2/8VP2360	236	16.41	2/8VP3750	375	26.08			
3/8VP1500	150	15.65	3/8VP2360	236	24.62	3/8VP3750	375	39.12			
4/8VP1500	150	20.86	4/8VP2360	236	32.83	4/8VP3750	375	52.16			
5/8VP1500	150	26.08	5/8VP2360	236	41.03	5/8VP3750	375	65.20			

Available up to 12 strands. 6-12 strands made to order.

# DRIVE SELECTION – NARROW BELTS



An Altra Industrial Motion Company

## 1. Determine DESIGN HORSEPOWER

DESIGN HORSEPOWER = DriveR HP x Service Factor (See below)

## SERVICE FACTORS

DRIVEN MACHINE See Note 1	DRIVER					
	AC Normal Torque Electric Motor (NEMA Design A-B) See Note 2			AC High Torque Electric Motor (NEMA Design C-D) See Note 3		
	Intermittent Service See Note 4	Normal Service See Note 5	Continuous Service See Note 6	Intermittent Service See Note 4	Normal Service See Note 5	Continuous Service See Note 6
Agitators for Liquids . . . . .						
Blowers and Exhausters . . . . .						
Centrifugal Pumps and Compressors . . . . .	1.0	1.1	1.2	1.1	1.2	1.3
Conveyors (Light Duty) . . . . .						
Fans (up to 10 H.P.) . . . . .						
Belt Conveyors for Sand, Grain, etc. . . . .						
Fans (over 10 H.P.) . . . . .						
Generators . . . . .						
Laundry Machinery . . . . .						
Line Shafts . . . . .						
Machine Tools . . . . .	1.1	1.2	1.3	1.2	1.3	1.4
Mixers (Dough) . . . . .						
Positive Displacement Rotary Pumps . . . . .						
Printing Machinery . . . . .						
Punches-Presses-Shears See Note 1 . . . . .						
Revolving and Vibrating Screens . . . . .						
Blowers (Positive Displacement) . . . . .						
Brick Machinery . . . . .						
Compressors (Piston) See Note 1 . . . . .						
Conveyors (Drag-Pan-Screw) . . . . .						
Elevators (Bucket) . . . . .						
Exciters . . . . .	1.2	1.3	1.4	1.4	1.5	1.6
Hammer Mills . . . . .						
Paper Mill Beaters . . . . .						
Pulverizes . . . . .						
Pumps (Piston) . . . . .						
Saw Mill and Woodworking Machinery . . . . .						
Textile Machinery . . . . .						
Crushers (Gyratory-Jaw-Roll) See Note 1 . . . . .	1.3	1.4	1.5	1.5	1.6	1.8
Mills (Ball-Rod-Tube) See Note 1 . . . . .						
Hoists See Note 1 . . . . .						
Rubber Calenders-Extruders-Mills See Note 1						

**Note 1** The Driven Machines listed above are representative samples only. When one of the sheaves of the drive is used as a flywheel to reduce speed fluctuations and equalize the energy exerted at the shaft or for applications involving impact or jam loads specially constructed sheaves may be required. Consult the manufacturer.

**Note 2** Included under this heading are the following electric motors: Synchronous and Squirrel Cage AC Normal Torque, AC Split Phase, DC Shunt Wound and Internal Combustion Engines.

**Note 3** Included under this heading are the following electric motors: AC High Torque, AC Hi-Slip, AC Repulsion, Induction, AC Single Phase Series Wound, AC Slip Ring and DC Compound Wound.

**Note 4** Intermittent Service refers to 3–5 hours of daily or seasonal operation.

**Note 5** Normal Service indicates 8–10 hours of daily operation.

**Note 6** Continuous Service refers to 16–24 hours of daily operation.

**Note 7** If idlers are used, add the following to the service factor.

Idler on slack side (inside)	None
Idler on slack side (outside)	0.1
Idler on tight side (inside)	0.1
Idler on tight side (outside)	0.2

2. Select **BELT CROSS SECTION** using chart below.

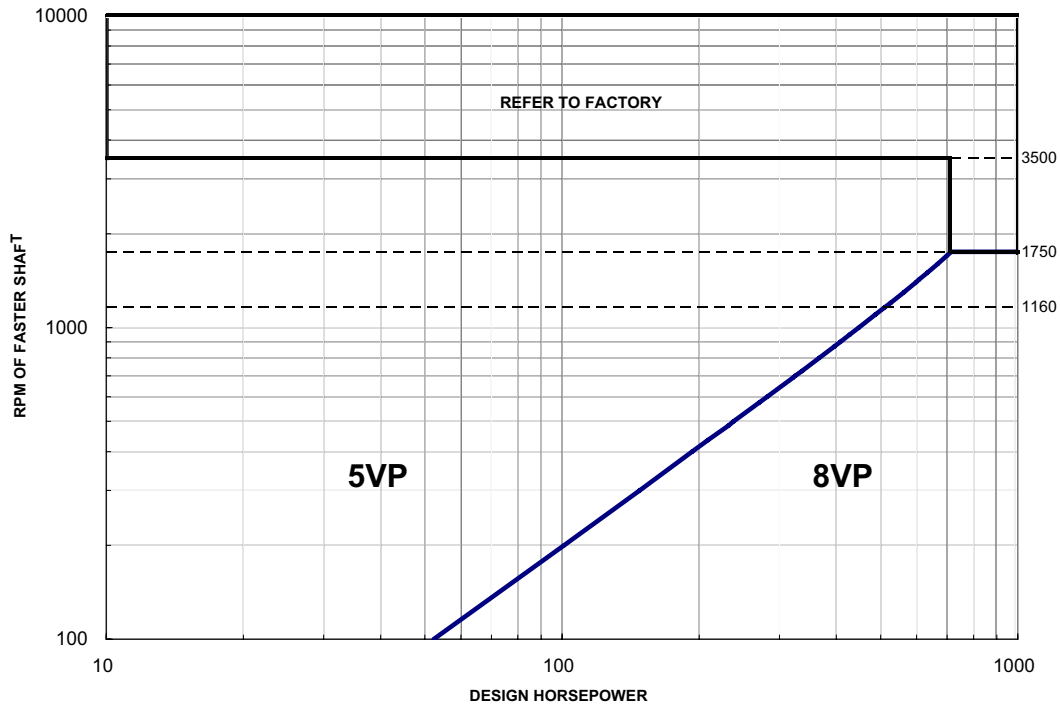

3. If using a 60 HZ electric motor, **Note the Minimum Motor Sheave Outside Diameter recommended by NEMA.**

Motor Horsepower	MOTOR RPM			
	870	1160	1750	3500
1/2	2.2	...	...	...
3/4	2.4	2.2	...	...
1	2.4	2.4	2.2	...
1-1/2	2.4	2.4	2.4	2.2
2	3.0	2.4	2.4	2.4
3	3.0	3.0	2.4	2.4
5	3.8	3.0	3.0	2.4
7-1/2	4.4	3.8	3.0	3.0
10	4.4	4.4	3.8	3.0
15	5.2	4.4	4.4	3.8
20	6.0	5.2	4.4	4.4
25	6.8	6.0	4.4	4.4
30	6.8	6.8	5.2	...
40	8.2	6.8	6.0	...
50	8.4	8.2	6.8	...
60	10.0	8.2	7.4	...
75	10.0	10.0	8.6	...
100	12.0	10.0	8.6	...
125	...	12.0	10.5	...
150	...	...	10.5	...
200	...	...	13.2	...
250	...	...	...	...
300	...	...	...	...

# DRIVE SELECTION - NARROW BELTS



An Altra Industrial Motion Company

- BELT LENGTH =  $2 \times C + 1.57 \times (D + d) + [(D - d)^2 / 4 \times C]$
- CENTER DISTANCE =  $1/2 \times [A - h \times (D - d)]$

WHERE:

C = Center Distance (in.)      D = O.D. of larger sheave (in.)  
 L = Belt Length (in.)          d = O.D. of smaller sheave (in.)  
 A =  $L - 1.57 \times (D + d)$       h = Factor from chart below

$\frac{D-d}{A}$	h	$\frac{D-d}{A}$	h	$\frac{D-d}{A}$	h	$\frac{D-d}{A}$	h
0.00	0.00	0.16	0.08	0.30	0.16	0.43	0.24
0.02	0.01	0.18	0.09	0.32	0.17	0.44	0.25
0.04	0.02	0.20	0.10	0.34	0.18	0.46	0.26
0.06	0.03	0.21	0.11	0.35	0.19	0.47	0.27
0.08	0.04	0.23	0.12	0.37	0.20	0.48	0.28
0.10	0.05	0.25	0.13	0.39	0.21	0.50	0.29
0.12	0.06	0.27	0.14	0.40	0.22	0.51	0.30
0.14	0.07	0.29	0.15	0.41	0.23	...	...

## AC FACTORS

$\frac{D-d}{C}$	Factor Ac	$\frac{D-d}{C}$	Factor Ac
0.000	1.000	0.750	0.879
0.025	0.997	0.775	0.874
0.050	0.994	0.800	0.869
0.075	0.990	0.825	0.864
0.100	0.987	0.850	0.858
0.125	0.983	0.875	0.852
0.150	0.980	0.900	0.847
0.175	0.977	0.925	0.841
0.200	0.973	0.950	0.835
0.225	0.969	0.975	0.829
0.250	0.966	1.000	0.823
0.275	0.962	1.025	0.816
0.300	0.958	1.050	0.810
0.325	0.954	1.075	0.803
0.350	0.951	1.100	0.796
0.375	0.947	1.125	0.789
0.400	0.943	1.150	0.782
0.425	0.939	1.175	0.774
0.450	0.935	1.200	0.767
0.475	0.930	1.225	0.759
0.500	0.926	1.250	0.751
0.525	0.922	1.275	0.742
0.550	0.917	1.300	0.734
0.575	0.913	1.325	0.725
0.600	0.908	1.350	0.716
0.625	0.904	1.375	0.706
0.650	0.899	1.400	0.697
0.675	0.894	1.425	0.687
0.700	0.889		
0.725	0.884		

## LC FACTORS

Belt No.	Correction Factor Lc	Belt No.	Correction Factor Lc	Belt No.	Correction Factor Lc
3VP450	.94	5VP600	.88	8VP1000	.87
3VP475	.95	5VP630	.89	8VP1060	.88
3VP500	.96	5VP670	.90	8VP1120	.88
3VP530	.97	5VP710	.91	8VP1180	.89
3VP560	.98	5VP750	.92	8VP1250	.90
3VP600	.99	5VP800	.93	8VP1320	.91
3VP630	1.00	5VP850	.94	8VP1400	.92
3VP670	1.01	5VP900	.95	8VP1500	.93
3VP710	1.02	5VP950	.95	8VP1600	.94
3VP750	1.03	5VP1000	.96	8VP1700	.94
3VP800	1.04	5VP1060	.97	8VP1800	.95
3VP850	1.05	5VP1120	.98	8VP1900	.96
3VP900	1.07	5VP1180	.99	8VP2000	.97
3VP950	1.08	5VP1250	1.00	8VP2120	.97
3VP1000	1.09	5VP1320	1.01	8VP2240	.98
3VP1060	1.10	5VP1400	1.02	8VP2360	.99
3VP1120	1.11	5VP1500	1.03	8VP2500	1.00
3VP1180	1.12	5VP1600	1.04	8VP2650	1.01
3VP1250	1.13	5VP1700	1.05	8VP2800	1.02
3VP1320	1.14	5VP1800	1.06	8VP3000	1.02
3VP1400	1.15	5VP1900	1.07	8VP3150	1.03
		5VP2000	1.08	8VP3350	1.04
		5VP2120	1.09	8VP3550	1.05
		5VP2240	1.09	8VP3750	1.06
		5VP2360	1.10	8VP4000	1.07
		5VP2500	1.11	8VP4250	1.08
		5VP2650	1.12	8VP4500	1.09
		5VP2800	1.13	8VP4750	1.09
		5VP3000	1.14	8VP5000	1.10
		5VP3150	1.15		
		5VP3350	1.16		
		5VP3550	1.17		

Proper balance of rotating products is important for smooth, vibration-free operation. Standard balance of Wood's stock products is a one plane balance. Depending on the face width, outside diameter, and operating speed a higher precision balance may be required for smooth operation. In those cases a two-plane balance is suggested.

**Note: Two plane balance is for smooth operation only and DOES NOT increase the maximum safe operating speed of the product. Stock cast iron wheels may not exceed 6,550 feet per minute; and ductile iron wheels are limited to 10,000 FPM. (FPM = sheave outside diameter x RPM x .262)**

The nomograph below may be used as a guideline to determine when two-plane balance is recommended. To use this chart lay a straight-edge between the diameter of the part on the left of the chart and the face width of the part on the right. The straight edge will intersect the slanted scale in the center of the chart. When the operating speed is greater than the intersection point a two-plane balance is recommended.

**Example:** If a 20 in. diameter x 10 in. face width sheave runs faster than 1100 rpm, dynamic balancing is recommended.

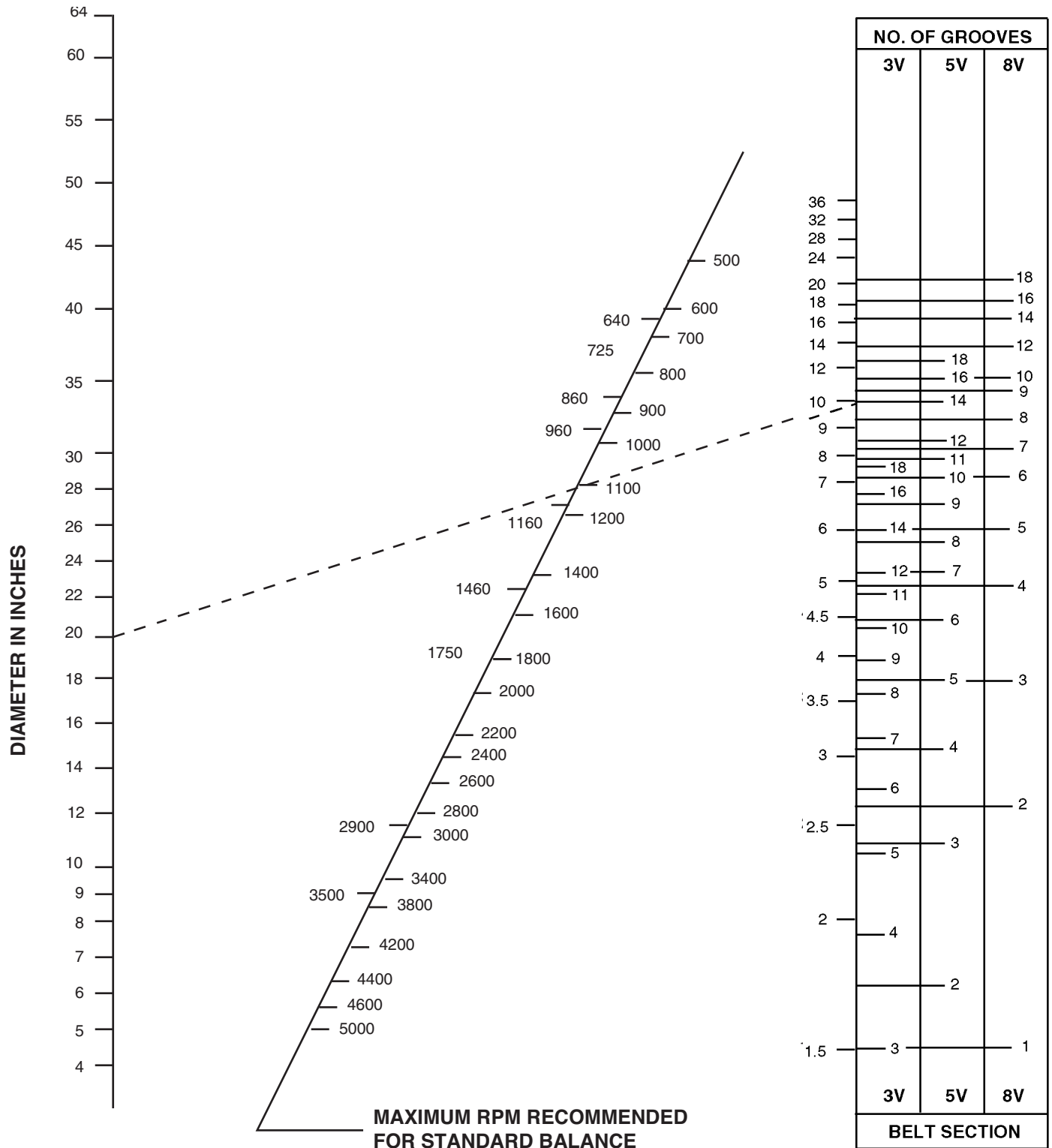

# DRIVE SELECTION – NARROW Premium-V BELTS

## Drive Design

Example: Given a 1000 HP engine at 900 RPM driving a Jaw Crusher operating at 320 RPM, 8 hours per day. The engine shaft is 5-7/8”, the Crusher shaft is 8”, and the center distance is 80”.

Procedure		Example																
Step #1	<b>Calculate the Design Horsepower</b> DHP=DriveR HP x service Factor (page BP1-15)	Service Factor = 1.6 DHP = 1000 x 1.6 = 1600																
Step #2	<b>Choose the Belt Cross Section</b> Reference chart (page BP1-16)	1600 DHP and 900 RPM intersect in the 8VP section.																
Step #3	<b>Check NEMA recommended Minimum Motor Sheave Outside Diameter</b> (page BP1-16)	Not Applicable with Internal Combustion Engine																
Step #4	<b>Calculate Speed Ratio</b> Speed Ratio = Faster RPM/Slower RPM	Speed Ratio = 900 RPM / 320 RPM = 2.81																
Step #5	<b>Use the Ratio and any diameter limits or known sheaves to determine the diameters of DriveR and DriveN. Try to utilize stock parts when possible.</b>	22.4 DriveR Sheave x 2.81 Ratio = 62.9 DriveN Sheave Use Stock 8VP63.0 stock sheave																
Step #6	<b>Using the diameter of the sheave the actual ratio and speed can be calculated.</b>	Actual Ratio = 63.0 DriveN / 22.4 DriveR = 2.81 Actual RPM = 900 RPM DriveR / 2.81 = 320 RPM DriveN																
Step #7	<b>Calculate Belt Length to determine the closest stock belt. Then calculate the actual CD using the stock belt.</b> (Formulas on page BP1-17)	BL = 2 x 80 + 1.57 x (63.0 + 22.4) + [(63.0-22.4) <sup>2</sup> / (4 x 80)] BL = 299.2 – Use an 8VP3000 Belt A = 300 – 1.57 x (63.0 + 22.4) = 165.9 CD = ½ x [165.9 - .13 x (63.0 – 22.4)] = 80.3”																
Step #8	<b>Find the AC and LC correction factors.</b> (page BP1-17)	AC factor = .926 LC factor for 8VP3000 belts = 1.02																
Step #9	<b>In the HP Rating Tables, following the Drive Selection Tables, locate the HP per Belt under the correct Belt Section.</b> (Use Small Sheave Diameter and RPM)	8VP rating tables (page BP1-24 to -25) 22.4 diameter @ 900 RPM HP / Belt = 177.7																
Step #10	<b>Calculate corrected HP per Belt</b> Add on for ratio is found to the right of the HP Rating Tables CHP = (HP per Belt + Add on) x AC x LC	Add on for 2.81 ratio = 6.20 CHP = (177.7 + 6.20) x .926 x 1.02 = 173.7																
Step #11	<b>Determine the number of belts required</b> NOB = Design HP/CHP	NOB = 1600 DHP / 173.7 CHP = 9.21 Use 10 belts																
Step #12	<b>Check for Dynamic Balance Recommendations</b> Reference Chart (page BP1-18)	OK as Standard – 8V22.4 x 10 standard balance good to 1050 RPM OK as Standard – 8V63.0 x 10 standard balance good to 550 RPM																
Step #13	<b>Stock cast iron parts are good to 6500 FPM.</b> If operating faster MTO ductile iron is required. FPM = diameter (in.) x RPM x .262	FPM = 22.4 x 900 x .262 = 5282 FPM Standard Cast Iron parts are OK.																
Step #14	<b>Specify Drive Components</b> Reference Component Dimensional pages for Product Number	<table border="0"> <thead> <tr> <th>Item</th> <th>Product No.</th> </tr> </thead> <tbody> <tr> <td>DR - 8V22.4 x 10 sheave</td> <td>8V22410</td> </tr> <tr> <td>- N Bushing for 5-7/8” bore</td> <td>N578</td> </tr> <tr> <td>DN - 8V63.0 x 10 sheave</td> <td>8V63010</td> </tr> <tr> <td>- W Bushing for 8” bore</td> <td>MTO</td> </tr> <tr> <td>One 10 Banded Belt</td> <td>10/5VP3000</td> </tr> <tr> <td>or</td> <td></td> </tr> <tr> <td>Two 5 Banded Belts</td> <td>5/8VP3000</td> </tr> </tbody> </table>	Item	Product No.	DR - 8V22.4 x 10 sheave	8V22410	- N Bushing for 5-7/8” bore	N578	DN - 8V63.0 x 10 sheave	8V63010	- W Bushing for 8” bore	MTO	One 10 Banded Belt	10/5VP3000	or		Two 5 Banded Belts	5/8VP3000
Item	Product No.																	
DR - 8V22.4 x 10 sheave	8V22410																	
- N Bushing for 5-7/8” bore	N578																	
DN - 8V63.0 x 10 sheave	8V63010																	
- W Bushing for 8” bore	MTO																	
One 10 Banded Belt	10/5VP3000																	
or																		
Two 5 Banded Belts	5/8VP3000																	

Horsepower ratings per belt are listed below and on the facing page. To obtain the basic horsepower rating per belt, locate the RPM of the faster shaft in the left-hand column. Read on this line across to the column headed by the diameter of the smaller sheave. The figure given is the basic horsepower rating. For convenience the standard motor speeds are grouped at the beginning of the chart. On the same horizontal line read the "add-on" rating in the column headed by the drive speed ratio. Add the basic rating to the "add-on" rating to obtain the total horsepower rating per belt.

### Rated Horsepower per Belt -- For 5V Section Premium-V Belts

RPM of Faster Shaft	Basic Horsepower per Belt															
	Small Sheave Outside Diameter															
	7.10	7.50	8.00	8.50	9.00	9.25	9.75	10.30	10.90	11.30	11.80	12.50	13.20	14.00	15.00	16.00
435	7.47	8.48	9.74	11.0	12.2	12.9	14.1	15.5	17.0	18.0	19.2	20.9	22.6	24.6	27.0	29.4
485	8.25	9.37	10.8	12.2	13.5	14.2	15.6	17.1	18.8	19.9	21.2	23.2	25.1	27.2	29.9	32.6
575	9.61	10.9	12.6	14.2	15.8	16.7	18.3	20.1	22.0	23.3	24.9	27.1	29.3	31.9	35.0	38.2
690	11.3	12.9	14.8	16.8	18.7	19.7	21.6	23.7	26.0	27.5	29.4	32.1	34.7	37.7	41.4	45.1
725	11.8	13.5	15.5	17.5	19.6	20.6	22.6	24.8	27.2	28.8	30.8	33.6	36.3	39.4	43.3	47.2
870	13.9	15.9	18.3	20.7	23.1	24.3	26.7	29.3	32.1	34.0	36.3	39.6	42.8	46.5	51.0	55.5
950	15.0	17.1	19.8	22.4	25.0	26.3	28.9	31.7	34.8	36.8	39.3	42.8	46.3	50.3	55.2	60.0
1160	17.9	20.4	23.6	26.7	29.8	31.4	34.5	37.8	41.5	43.9	46.9	51.0	55.2	59.8	65.5	71.1
1425	21.3	24.3	28.1	31.9	35.6	37.5	41.2	45.2	49.5	52.3	55.9	60.7	65.5	70.9	77.5	83.9
1750	25.2	28.9	33.4	37.8	42.2	44.4	48.8	53.4	58.5	61.8	65.8	71.4	76.9	82.9	90.2*	
100	1.95	2.20	2.50	2.81	3.11	3.27	3.57	3.90	4.27	4.51	4.81	5.23	5.66	6.14	6.73	7.33
200	3.68	4.16	4.76	5.36	5.95	6.25	6.84	7.49	8.20	8.67	9.26	10.1	10.9	11.8	13.0	14.2
300	5.33	6.04	6.92	7.80	8.68	9.12	9.99	11.0	12.0	12.7	13.6	14.8	16.0	17.4	19.1	20.8
400	6.93	7.86	9.02	10.2	11.3	11.9	13.1	14.3	15.7	16.6	17.8	19.3	20.9	22.7	25.0	27.2
500	8.48	9.63	11.1	12.5	13.9	14.6	16.1	17.6	19.3	20.4	21.9	23.8	25.8	28.0	30.8	33.5
600	9.99	11.4	13.1	14.8	16.5	17.3	19.0	20.9	22.9	24.2	25.9	28.2	30.5	33.1	36.4	39.7
700	11.5	13.1	15.0	17.0	19.0	19.9	21.9	24.0	26.4	27.9	29.8	32.5	35.2	38.2	41.9	45.7
800	12.9	14.7	17.0	19.2	21.4	22.5	24.7	27.1	29.8	31.5	33.7	36.7	39.7	43.1	47.3	51.5
900	14.3	16.3	18.8	21.3	23.8	25.0	27.5	30.2	33.1	35.0	37.5	40.8	44.1	47.9	52.6	57.2
1000	15.7	17.9	20.7	23.4	26.2	27.5	30.2	33.2	36.4	38.5	41.2	44.8	48.5	52.6	57.7	62.7
1200	18.4	21.0	24.3	27.5	30.7	32.3	35.5	39.0	42.7	45.2	48.3	52.6	56.8	61.5	67.4	73.1
1400	21.0	24.0	27.7	31.4	35.1	36.9	40.5	44.5	48.7	51.6	55.0	59.9	64.6	69.9	76.4	82.7
1600	23.4	26.8	31.0	35.2	39.3	41.3	45.3	49.7	54.4	57.5	61.4	66.7	71.8	77.6	84.6	91.4*
1800	25.8	29.5	34.1	38.7	43.2	45.4	49.9	54.6	59.8	63.1	67.3	72.9	78.5	84.6*		
2000	28.0	32.1	37.1	42.0	46.9	49.3	54.1	59.2	64.7	68.3	72.7	78.7	84.4*			
2200	30.1	34.4	39.9	45.2	50.4	52.9	58.0	63.4	69.2	73.0*	77.5*					
2400	32.0	36.7	42.4	48.1	53.6	56.3	61.6	67.3	73.2*							
2600	33.8	38.7	44.8	50.7	56.5	59.3	64.8*									
2800	35.4	40.6	46.9	53.1	59.1*	62.0*										
3000	36.9	42.3	48.8	55.2*												

\* Made-to-order ductile iron sheave required



# HORSEPOWER RATINGS for 5VP BELTS



An Altra Industrial Motion Company

The combined Arc-Length correction factor shown in the Arc-of-Contact correction factor table and the Belt Length correction factor table, page BP1-17, should be applied to the total HP per belt before determining the number of belts required for the drive.

RPM of Faster Shaft	"Add-on" Horsepower rating per Belt									
	Speed Ratio									
	1.00	1.02	1.03	1.04	1.06	1.07	1.09	1.12	1.16	1.24
	1.01	1.02	1.03	1.05	1.06	1.08	1.11	1.15	1.23	over
435	0.00	0.06	0.11	0.17	0.23	0.29	0.34	0.40	0.46	0.52
485	0.00	0.06	0.13	0.19	0.26	0.32	0.38	0.45	0.51	0.58
575	0.00	0.08	0.15	0.23	0.30	0.38	0.45	0.53	0.61	0.68
690	0.00	0.09	0.18	0.27	0.36	0.45	0.55	0.64	0.73	0.82
725	0.00	0.10	0.19	0.29	0.38	0.48	0.57	0.67	0.76	0.86
870	0.00	0.11	0.23	0.34	0.46	0.57	0.69	0.80	0.92	1.03
950	0.00	0.13	0.25	0.38	0.50	0.63	0.75	0.88	1.00	1.13
1160	0.00	0.15	0.31	0.46	0.61	0.76	0.92	1.07	1.22	1.38
1425	0.00	0.19	0.38	0.56	0.75	0.94	1.13	1.31	1.50	1.69
1750	0.00	0.23	0.46	0.69	0.92	1.15	1.38	1.61	1.84	2.08
100	0.00	0.01	0.03	0.04	0.05	0.07	0.08	0.09	0.11	0.12
200	0.00	0.03	0.05	0.08	0.11	0.13	0.16	0.18	0.21	0.24
300	0.00	0.04	0.08	0.12	0.16	0.20	0.24	0.28	0.32	0.36
400	0.00	0.05	0.11	0.16	0.21	0.26	0.32	0.37	0.42	0.47
500	0.00	0.07	0.13	0.20	0.26	0.33	0.40	0.46	0.53	0.59
600	0.00	0.08	0.16	0.24	0.32	0.40	0.47	0.55	0.63	0.71
700	0.00	0.09	0.18	0.28	0.37	0.46	0.55	0.65	0.74	0.83
800	0.00	0.11	0.21	0.32	0.42	0.53	0.63	0.74	0.84	0.95
900	0.00	0.12	0.24	0.36	0.47	0.59	0.71	0.83	0.95	1.07
1000	0.00	0.13	0.26	0.40	0.53	0.66	0.79	0.92	1.05	1.19
1200	0.00	0.16	0.32	0.47	0.63	0.79	0.95	1.11	1.26	1.42
1400	0.00	0.18	0.37	0.55	0.74	0.92	1.11	1.29	1.48	1.66
1600	0.00	0.21	0.42	0.63	0.84	1.05	1.26	1.48	1.69	1.90
1800	0.00	0.24	0.47	0.71	0.95	1.19	1.42	1.66	1.90	2.13
2000	0.00	0.26	0.53	0.79	1.05	1.32	1.58	1.84	2.11	2.37
2200	0.00	0.29	0.58	0.87	1.16	1.45	1.74	2.03	2.32	2.61
2400	0.00	0.32	0.63	0.95	1.27	1.58	1.90	2.21	2.53	2.85
2600	0.00	0.34	0.69	1.03	1.37	1.71	2.06	2.40	2.74	3.08
2800	0.00	0.37	0.74	1.11	1.48	1.84	2.21	2.58	2.95	3.32
3000	0.00	0.40	0.79	1.19	1.58	1.98	2.37	2.77	3.16	3.56

Horsepower ratings per belt are listed below and on the facing page. To obtain the basic horsepower rating per belt, locate the RPM of the faster shaft in the left-hand column. Read on this line across to the column headed by the diameter of the smaller sheave. The figure given is the basic horsepower rating. For convenience the standard motor speeds are grouped at the beginning of the chart. On the same horizontal line read the "add-on" rating in the column headed by the drive speed ratio. Add the basic rating to the "add-on" rating to obtain the total horsepower rating per belt.

## Rated Horsepower per Belt -- For 8V Section Premium-V Belts

RPM of Faster Shaft	Basic Horsepower per Belt for Small Sheave Outside Diameter										
	12.50	13.20	14.00	15.00	16.00	17.00	18.00	19.00	20.00	21.20	22.40
435	26.6	31.5	37.1	44.1	51.0	57.9	64.8	71.6	78.4	86.6	94.7
485	29.2	34.7	40.8	48.5	56.2	63.9	71.5	79.0	86.5	95.5	104.5
575	33.7	40.1	47.4	56.4	65.4	74.3	83.2	92.0	100.8	111.2	121.6
690	39.3	46.8	55.4	66.0	76.6	87.1	97.6	107.9	118.2	130.4	142.5
725	40.9	48.8	57.7	68.9	79.9	90.9	101.8	112.6	123.3	136.1	148.7
870	47.3	56.6	67.1	80.2	93.2	106.0	118.7	131.3	143.7	158.4	172.9
950	50.6	60.7	72.1	86.2	100.1	113.9	127.5	141.0	154.3	170.0	185.4
1160	58.6	70.5	84.0	100.6	116.9	133.0	148.8	164.3	179.5	197.3	214.7*
1425	67.0	81.0	96.8	116.1	134.9	153.3	171.2*				
1750	74.5	90.6	108.6	130.4*							
50	3.90	4.52	5.22	6.10	6.97	7.84	8.71	9.58	10.4	11.5	12.5
100	7.28	8.48	9.85	11.6	13.3	15.0	16.7	18.3	20.0	22.1	24.1
150	10.5	12.2	14.3	16.8	19.3	21.8	24.3	26.8	29.3	32.3	35.2
200	13.5	15.8	18.5	21.8	25.1	28.4	31.7	35.0	38.3	42.2	46.1
250	16.4	19.3	22.6	26.7	30.8	34.9	39.0	43.1	47.1	52.0	56.8
300	19.3	22.7	26.7	31.6	36.4	41.3	46.1	51.0	55.8	61.6	67.3
400	24.8	29.3	34.5	40.9	47.3	53.7	60.0	66.4	72.7	80.2	87.7
500	30.0	35.6	41.9	49.9	57.8	65.6	73.4	81.2	89.0	98.2	107.4
600	35.0	41.6	49.1	58.5	67.9	77.1	86.4	95.5	104.6	115.5	126.3
700	39.7	47.4	56.1	66.9	77.6	88.2	98.8	109.3	119.7	132.1	144.3
800	44.2	52.9	62.7	74.8	86.9	98.9	110.7	122.4	134.1	147.9	161.5
900	48.5	58.1	69.0	82.5	95.8	109.0	122.1	135.0	147.7	162.8	177.7
1000	52.6	63.1	75.0	89.8	104.3	118.7	132.9	146.8	160.6	176.9	192.8
1100	56.4	67.8	80.7	96.6	112.3	127.8	143.0	158.0	172.7	190.0	206.8
1200	60.0	72.2	86.1	103.1	119.9	136.3	152.5	168.4	183.9	202.0*	
1300	63.3	76.3	91.1	109.2	126.9	144.3	161.3	177.9	194.1*		
1400	66.3	80.1	95.7	114.7	133.4	151.6	169.3*	186.6*			
1500	69.0	83.6	99.9	119.9	139.3	158.2*					
1600	71.4	86.6	103.7	124.5	144.6*						
1700	73.5	89.4	107.1	128.6*							

\* Made-to-order ductile iron sheave required

# HORSEPOWER RATINGS for 8VP BELTS



An Altra Industrial Motion Company

The combined Arc-Length correction factor shown in the Arc-of-Contact correction factor table and the Belt Length correction factor table, page BP1-17, should be applied to the total HP per belt before determining the number of belts required for the drive.

RPM of Faster Shaft	"Add-on" Horsepower rating per Belt									
	Speed Ratio									
	1.00	1.02	1.03	1.04	1.06	1.07	1.09	1.12	1.16	1.24
	1.01	1.02	1.03	1.05	1.06	1.08	1.11	1.15	1.23	over
435	0.00	0.33	0.67	1.00	1.33	1.66	2.00	2.33	2.66	3.00
485	0.00	0.37	0.74	1.11	1.48	1.86	2.23	2.60	2.97	3.34
575	0.00	0.44	0.88	1.32	1.76	2.20	2.64	3.08	3.52	3.96
690	0.00	0.53	1.06	1.58	2.11	2.64	3.17	3.70	4.22	4.75
725	0.00	0.55	1.11	1.66	2.22	2.77	3.33	3.88	4.44	4.99
870	0.00	0.67	1.33	2.00	2.66	3.33	3.99	4.66	5.33	5.99
950	0.00	0.73	1.45	2.18	2.91	3.64	4.36	5.09	5.82	6.54
1160	0.00	0.89	1.78	2.66	3.55	4.44	5.33	6.21	7.10	7.99
1425	0.00	1.09	2.18	3.27	4.36	5.45	6.54	7.63	8.72	9.81
1750	0.00	1.34	2.68	4.02	5.36	6.70	8.04	9.37	10.71	12.05
50	0.00	0.04	0.08	0.11	0.15	0.19	0.23	0.27	0.31	0.34
100	0.00	0.08	0.15	0.23	0.31	0.38	0.46	0.54	0.61	0.69
150	0.00	0.11	0.23	0.34	0.46	0.57	0.69	0.80	0.92	1.03
200	0.00	0.15	0.31	0.46	0.61	0.77	0.92	1.07	1.22	1.38
250	0.00	0.19	0.38	0.57	0.77	0.96	1.15	1.34	1.53	1.72
300	0.00	0.23	0.46	0.69	0.92	1.15	1.38	1.61	1.84	2.07
400	0.00	0.31	0.61	0.92	1.22	1.53	1.84	2.14	2.45	2.76
500	0.00	0.38	0.77	1.15	1.53	1.91	2.30	2.68	3.06	3.44
600	0.00	0.46	0.92	1.38	1.84	2.30	2.76	3.21	3.67	4.13
700	0.00	0.54	1.07	1.61	2.14	2.68	3.21	3.75	4.29	4.82
800	0.00	0.61	1.22	1.84	2.45	3.06	3.67	4.29	4.90	5.51
900	0.00	0.69	1.38	2.07	2.76	3.44	4.13	4.82	5.51	6.20
1000	0.00	0.76	1.53	2.30	3.06	3.83	4.59	5.36	6.12	6.89
1100	0.00	0.84	1.68	2.52	3.37	4.21	5.05	5.89	6.73	7.58
1200	0.00	0.92	1.84	2.75	3.67	4.59	5.51	6.43	7.35	8.27
1300	0.00	0.99	1.99	2.98	3.98	4.97	5.97	6.96	7.96	8.95
1400	0.00	1.07	2.14	3.21	4.29	5.36	6.43	7.50	8.57	9.64
1500	0.00	1.15	2.30	3.44	4.59	5.74	6.89	8.04	9.18	10.33
1600	0.00	1.22	2.45	3.67	4.90	6.12	7.35	8.57	9.79	11.02
1700	0.00	1.30	2.60	3.90	5.20	6.51	7.81	9.11	10.41	11.71

# NOTES

Lined area for notes, consisting of 22 horizontal lines.

# Classical (Premium) Drives

**BP2**

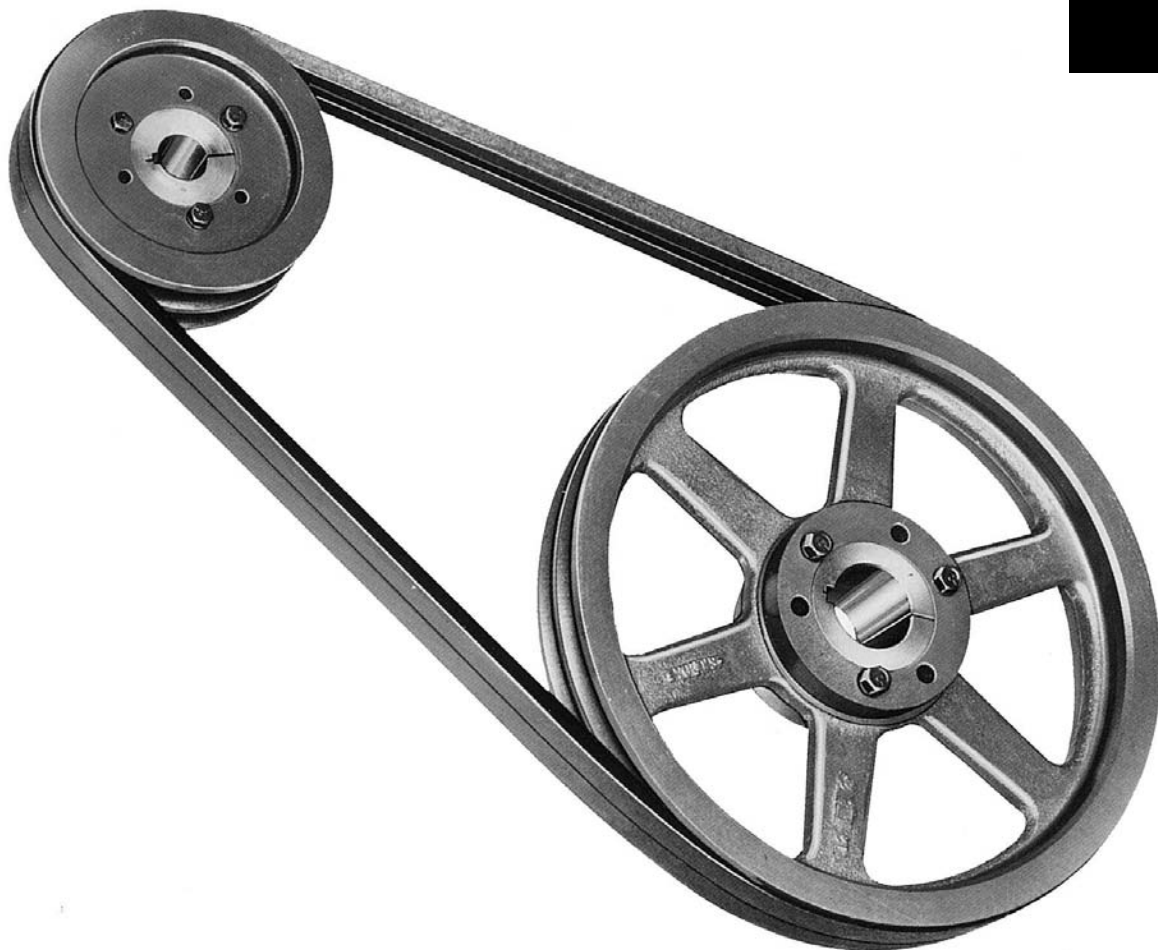

**For Tough Applications**

## CLASSICAL SHEAVE FEATURES

Wood's sheaves are constructed of fine grain, high tensile cast iron, and have been carefully engineered to assure maximum performance over a long life span. Behind each sheave is one of the most extensive engineering design and testing programs in the industry.

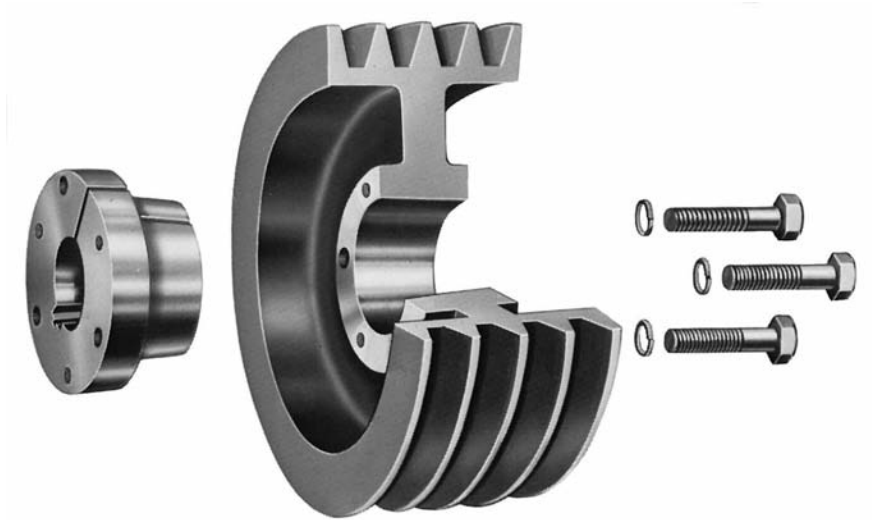

With the advent of higher V-belt ratings, Wood's engineers instituted additional careful test programs to ensure that each Wood's sheave would be capable of safely and dependably delivering the increased performance which was required by the new ratings. Wood's engineers, using a special strain gage test stand, subject sheaves to tension and compression stresses far in excess of those encountered in actual operation.

In another standard test procedure, Wood's sheaves are operated at extremely high speeds. Sheaves are selected from warehouse stocks and tested until they are burst by centrifugal force. Such destructive testing allows Wood's engineers to study the effects of construction and balance on sheave performance. The goal is to assure safe operation at normal speeds. Other continuing programs check product quality in the laboratory and on the manufacturing line.

For applications with special requirements, Wood's sheaves are also available on a made-to-order basis in either cast or ductile iron, and in Sure-Grip or bored-to-suit construction.

Wood's stock classical sheaves are available with the convenient Sure-Grip QD type bushing. Easy to install and remove, these split, tapered bushings grip the shaft with the equivalent of a shrink fit. This tight holding power eliminates freezing and fretting corrosion between the shaft and the bore and assures quick removal and interchangeability when necessary.

Stock sheaves are designed to carry the loads of all belts shown in this catalog and other similarly rated V-Belts. For special higher rated V-Belts, consult Wood's Engineering Department for recommendations.

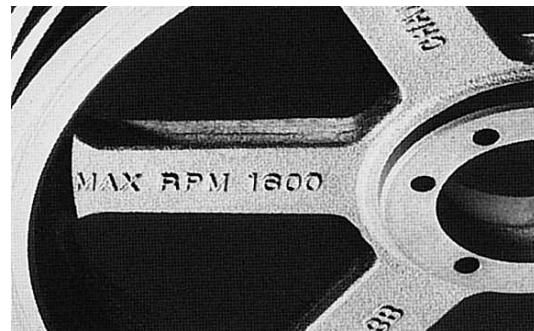

**We cast or stamp the maximum safe operating speed, in rpm, on all sheaves we manufacture.**

# CLASSICAL (CONVENTIONAL) SHEAVE GROOVE DETAILS

## STANDARD GROOVE DIMENSIONS

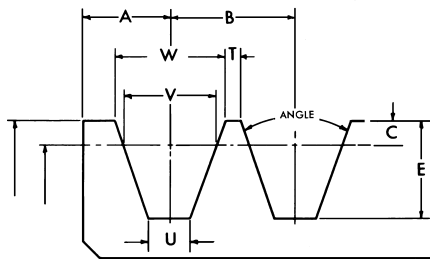

V-Belt	GROOVE DIMENSIONS IN INCHES										
	A	B	C	D	E	V	T	U	W	Angle of Groove	Used on Datums
A-B	1/2	3/4	.175	.206	.6125	.5053	.1377	.2379	.6123	34°	3.4 to 7.0
							.1241	.2040	.6259	38°	Over 7.0
C	11/16	1	.200	.200	.780	.757	.121	.402	.879	34°	7.0 to 7.9
							.113	.380	.887	36°	8.0 to 12.0
							.105	.358	.895	38°	Over 12.0
D	7/8	17/16	.300	.300	1.050	1.076	.1785	.617	1.259	34°	12.0 to 12.9
							.1665	.589	1.271	36°	13.0 to 17.0
							.1545	.550	1.283	38°	Over 17.0

## STANDARD SHEAVE FACE WIDTHS

Groove Section	FACE WIDTH OF SHEAVE IN INCHES																		
	1	2	3	4	5	6	7	8	9	10	11	12	13	14	15	16	17	18	For Each Additional Groove Add
A	3/4	1 3/8	2	2 5/8	3 1/4	3 7/8	4 1/2	5 1/8	5 3/4	6 3/8	7	7 5/8	8 1/4	8 7/8	9 1/2	10 1/8	10 3/4	11 3/8	5/8
B	1	1 3/4	2 1/2	3 1/4	4	4 3/4	5 1/2	6 1/4	7	7 3/4	8 1/2	9 1/4	10	10 3/4	11 1/2	12 1/4	13	13 3/4	3/4
C	1 3/8	2 3/8	3 3/8	4 3/8	5 3/8	6 3/8	7 3/8	8 3/8	9 3/8	10 3/8	11 3/8	12 3/8	13 3/8	14 3/8	15 3/8	16 3/8	17 3/8	18 3/8	1
D	1 3/4	3 3/16	4 5/8	6 1/16	7 1/2	8 15/16	10 3/8	11 13/16	13 1/4	14 11/16	16 1/8	17 9/16	19	20 7/16	21 7/8	23 13/16 *	25 1/4 *	26 11/16 *	1 7/16

\* Sheaves 16D groove and over have 1/2 inch added to overall face width. All dimensions in inches.

## DEEP GROOVE DIMENSIONS

V-Belt	GROOVE DIMENSIONS IN INCHES										
	A	B	C	D	E	V	T	U	W	Angle of Groove	Used on Datums
B	9/16	7/8	.355	.065	.7925	.5053	.153	.262	.747	34	4.6 to 7.0
							.125	.228	.774	38	Over 7.0
C	13/16	1 1/4	.505	.200	1.085	.757	.1840	.402	1.066	34	7.0 to 7.99
							.165	.380	1.085	36	8.0 to 12.0
							.145	.358	1.105	38	Over 12.0
D	1 1/16	1 3/4	.715	.300	1.465	1.076	.237	.617	1.513	34	12.0 to 12.99
							.209	.589	1.541	36	13.0 to 17.0
							.181	.560	1.569	38	Over 17.0

## DEEP GROOVE SHEAVE FACE WIDTHS

V-Belt	FACE WIDTH OF SHEAVE IN INCHES																		
	1	2	3	4	5	6	7	8	9	10	11	12	13	14	15	16	17	18	For Each Additional Groove Add
B	1 1/8	2	2 7/8	3 3/4	4 5/8	5 1/2	6 3/8	7 1/4	8 1/8	9	9 7/8	10 3/4	11 5/8	12 1/2	13 3/8	14 1/4	15 1/8	16	7/8
C	1 5/8	2 7/8	4 1/8	5 3/8	6 5/8	7 7/8	9 1/8	10 3/8	11 5/8	12 7/8	14 1/8	15 3/8	16 5/8	17 7/8	19 1/8	20 3/8	21 5/8	22 7/8	1 1/4
D	2 1/8	3 7/8	5 5/8	7 3/8	9 1/8	10 7/8	12 5/8	14 3/8	16 1/8	17 7/8	19 5/8	21 3/8	23 1/8	24 7/8	26 5/8	28 3/8	30 1/8	31 7/8	1 3/4

These Classical Sheaves are designed to carry the loads of all belts shown in this catalog and other similarly rated V-Belts. For special higher rated V-Belts, consult Wood's Application Engineering Department for recommendations.

The sheaves listed below are all stock sizes. The dimensions given are with the Sure-Grip bushing in place. The figure following the letter in the "Type" column indicates the sheave construction: 1–Solid; 2–Web, 3–Arms.

### DIMENSIONS (In Inches)

Datum Dia.		O.D.	I.D.	Product No.	1 GROOVE							Product No.	2 GROOVE						
A Belts	B Belts				F = 7/8 & 1								F = 1-3/4						
					E *	Type	Bush.	K	L	M	Wt.		E *	Type	Bush.	K	L	M	Wt.
3.0	3.4	3.75	2.12	<b>341B</b>	1/2	D1	SH	1/16	1-1/4	1/8	1.8	<b>342B</b>	1-1/16	E1	SH	0	1-1/4	9/16	2.9
3.2	3.6	3.95	2.25	<b>361B</b>	1/2	D1	SH	1/16	1-1/4	1/8	2.1	<b>362B</b>	7/8	E1	SH	-3/16	1-1/4	3/8	3.2
3.4	3.8	4.15	2.44	<b>381B</b>	1/2	D1	SH	1/16	1-1/4	1/8	2.3	<b>382B</b>	7/8	E1	SH	-3/16	1-1/4	3/8	3.6
3.6	4.0	4.35	2.75	<b>401B</b>	1/4	C1	SH	5/16	1-1/4	1/8	2.8	<b>402B</b>	1/8	A1	SH	11/16	1-1/4	3/8	3.8
3.8	4.2	4.55	2.94	<b>421B</b>	1/4	C1	SH	5/16	1-1/4	1/8	3.0	<b>422B</b>	1/8	A1	SH	11/16	1-1/4	3/8	4.3
4.0	4.4	4.75	3.12	<b>441B</b>	1/4	C1	SH	5/16	1-1/4	1/8	3.3	<b>442B</b>	1/8	A1	SH	11/16	1-1/4	3/8	4.7
4.2	4.6	4.95	3.38	<b>461B</b>	5/16	C1	SDS	5/16	1-5/16	1/8	3.8	<b>462B</b>	1/16	A1	SDS	11/16	1-5/16	3/8	4.8
4.4	4.8	5.15	3.38	<b>481B</b>	5/16	C1	SDS	5/16	1-5/16	1/8	3.8	<b>482B</b>	1/16	A1	SDS	11/16	1-5/16	3/8	5.5
4.6	5.0	5.35	3.62	<b>501B</b>	5/16	C1	SDS	5/16	1-5/16	1/8	4.1	<b>502B</b>	1/16	A1	SDS	11/16	1-5/16	3/8	5.6
4.8	5.2	5.55	3.69	<b>521B</b>	5/16	C1	SDS	5/16	1-5/16	1/8	4.3	<b>522B</b>	1/16	A1	SDS	11/16	1-5/16	3/8	6.6
5.0	5.4	5.75	4.00	<b>541B</b>	5/16	C1	SDS	5/16	1-5/16	1/8	4.6	<b>542B</b>	1/16	A1	SDS	11/16	1-5/16	3/8	6.5
5.2	5.6	5.95	4.31	<b>561B</b>	5/16	C1	SDS	5/16	1-5/16	1/8	5.1	<b>562B</b>	1/16	A1	SDS	11/16	1-5/16	3/8	7.4
5.4	5.8	6.15	4.41	<b>581B</b>	5/16	C1	SDS	5/16	1-5/16	1/8	5.3	<b>582B</b>	1/16	A1	SDS	11/16	1-5/16	3/8	7.6
5.6	6.0	6.35	4.50	<b>601B</b>	5/16	C1	SDS	5/16	1-5/16	1/8	5.6	<b>602B</b>	1/16	A1	SDS	11/16	1-5/16	3/8	8.2
5.8	6.2	6.55	4.81	<b>621B</b>	5/16	C1	SDS	5/16	1-5/16	1/8	5.8	<b>622B</b>	1/16	A1	SDS	11/16	1-5/16	3/8	8.5
6.0	6.4	6.75	4.88	<b>641B</b>	5/16	C1	SDS	5/16	1-5/16	1/8	6.2	<b>642B</b>	1/16	A1	SDS	11/16	1-5/16	3/8	9.2
6.2	6.6	6.95	5.22	<b>661B</b>	5/16	C1	SDS	5/16	1-5/16	0	7.4	<b>662B</b>	1/16	A1	SDS	11/16	1-5/16	3/8	9.5
6.4	6.8	7.15	5.31	<b>681B</b>	5/16	C1	SDS	5/16	1-5/16	0	7.9	<b>682B</b>	1/16	A1	SDS	11/16	1-5/16	3/8	10.3
6.6	7.0	7.35	5.50	<b>701B</b>	1/2	D2	SDS	1/8	1-5/16	3/16	6.8	<b>702B</b>	9/32	D1	SK	7/16	1-7/8	5/32	13.3
7.0	7.4	7.75	5.70	<b>741B</b>	1/2	D2	SDS	1/8	1-5/16	3/16	7.7	<b>742B</b>	9/32	D2	SK	7/16	1-7/8	5/32	14.7
7.6	8.0	8.35	6.63	<b>801B</b>	1/2	D2	SDS	1/8	1-5/16	3/16	8.5	<b>802B</b>	9/32	D2	SK	7/16	1-7/8	5/32	14.0
8.2	8.6	8.95	7.25	<b>861B</b>	1/2	D2	SDS	1/8	1-5/16	3/16	9.6	<b>862B</b>	9/32	D2	SK	7/16	1-7/8	5/32	15.3
9.0	9.4	9.75	8.00	<b>941B</b>	1/2	D3	SDS	1/8	1-5/16	3/16	8.9	<b>942B</b>	9/32	D3	SK	7/16	1-7/8	5/32	14.5
10.6	11.0	11.35	9.62	<b>1101B</b>	1/2	D3	SDS	1/8	1-5/16	3/16	11.7	<b>1102B</b>	9/32	D3	SK	7/16	1-7/8	5/32	17.0
12.0	12.4	12.75	11.06	<b>1241B</b>	1/2	D3	SDS	1/8	1-5/16	3/16	12.2	<b>1242B</b>	9/32	D3	SK	7/16	1-7/8	5/32	21.0
13.2	13.6	13.95	12.25	<b>1361B</b>	1/2	D3	SDS	1/8	1-5/16	3/16	14.0	<b>1362B</b>	9/32	D3	SK	7/16	1-7/8	5/32	23.1
15.0	15.4	15.75	14.00	<b>1541B</b>	19/32	C3	SK	1/8	1-7/8	9/32	20.3	<b>1542B</b>	9/32	D3	SK	7/16	1-7/8	5/32	28.7
15.6	16.0	16.35	14.62	<b>1601B</b>	19/32	C3	SK	1/8	1-7/8	9/32	18.4	<b>1602B</b>	9/32	D3	SK	7/16	1-7/8	5/32	25.5
18.0	18.4	18.75	17.00	<b>1841B</b>	19/32	C3	SK	1/8	1-7/8	9/32	23.7	<b>1842B</b>	9/32	D3	SK	7/16	1-7/8	5/32	29.6
19.6	20.0	20.35	18.50	<b>2001B</b>	19/32	C3	SK	1/8	1-7/8	9/32	30.7	<b>2002B</b>	5/16	D3	SF	3/8	2	1/16	43.5
24.6	25.0	25.35	23.38	<b>2501B</b>	11/16	C3	SF	0	2	1/4	44.0	<b>2502B</b>	5/16	D3	SF	3/8	2	1/16	53.7
29.6	30.0	30.35	28.50	<b>3001B</b>	11/16	C3	SF	0	2	1/4	55.0	<b>3002B</b>	5/16	D3	SF	3/8	2	1/16	64.7
37.6	38.0	38.35	36.38	...	...	...	...	...	...	...	...	<b>3802B</b>	5/16	D3	SF	3/8	2	1/16	97.9

\* "E" Dimension varies according to shaft tolerance.

Weights for all Sure-Grip bushed items are approximate and include the bushing.

Also available from stock made for the SF Bushing to accommodate larger bores.

P.D. for "A" Belts = DD + .25

P.D. for "B" Belts = DD + .413

**Sure-Grip Bushing dimensions — see section A1**



# STOCK CLASSICAL (CONVENTIONAL) SHEAVES

# A-B

# TB Wood's Incorporated

An Altra Industrial Motion Company

## DIMENSIONS (In Inches)

Datum Dia.		O.D.	I.D.	Product No.	3 GROOVE								Product No.	4 GROOVE							
A Belts	B Belts				F = 2-1/2									F = 3-1/4							
					E *	Type	Bush.	K	L	M	Wt.	E *		Type	Bush.	K	L	M	Wt.		
3.0	3.4	3.75	2.12	343B	1-13/16	E1	SH	0	1-1/4	9/16	3.7	344B	2-3/8	E1	SD	7/16	1-13/16	15/16	5.6		
3.2	3.6	3.95	2.25	363B	1-5/8	E1	SH	3/16	1-1/4	3/8	4.1	364B	2-3/8	E1	SD	7/16	1-13/16	15/16	6.2		
3.4	3.8	4.15	2.44	383B	1-5/8	E1	SH	3/16	1-1/4	3/8	4.5	384B	2-3/8	E1	SD	5/16	1-13/16	15/16	6.2		
3.6	4.0	4.35	2.75	403B	1/2	A1	SH	1-1/16	1-1/4	3/4	4.7	404B	2-1/16	E1	SD	0	1-13/16	5/8	6.5		
3.8	4.2	4.55	2.88	423B	1/2	A1	SH	1-1/16	1-1/4	3/4	5.3	424B	2-1/16	E1	SD	0	1-13/16	5/8	6.9		
4.0	4.4	4.75	3.12	443B	1/2	A1	SH	1-1/16	1-1/4	3/4	5.6	444B	2-1/16	E1	SD	0	1-13/16	5/8	7.4		
4.2	4.6	4.95	3.35	463B	7/16	A1	SD	1-1/16	1-13/16	1/4	6.8	464B	11/16	A1	SD	1-5/16	1-13/16	3/4	8.0		
4.4	4.8	5.15	3.44	483B	7/16	A1	SD	1-1/16	1-13/16	1/4	7.5	484B	11/16	A1	SD	1-5/16	1-13/16	3/4	8.8		
4.6	5.0	5.35	3.62	503B	7/16	A1	SD	1-1/16	1-13/16	1/4	8.1	504B	11/16	A1	SD	1-5/16	1-13/16	3/4	9.1		
4.8	5.2	5.55	3.81	523B	7/16	A1	SD	1-1/16	1-13/16	1/4	8.8	524B	11/16	A1	SD	1-5/16	1-13/16	3/4	10.2		
5.0	5.4	5.75	4.06	543B	7/16	A1	SD	1-1/16	1-13/16	1/4	9.3	544B	11/16	A1	SD	1-5/16	1-13/16	3/4	10.5		
5.2	5.6	5.95	4.25	563B	7/16	A1	SD	1-1/16	1-13/16	1/4	10.0	564B	11/16	A1	SD	1-5/16	1-13/16	3/4	11.3		
5.4	5.8	6.15	4.42	583B	7/16	A1	SD	1-1/16	1-13/16	1/4	10.7	584B	11/16	A1	SD	1-5/16	1-13/16	3/4	12.1		
5.6	6.0	6.35	4.68	603B	7/16	A2	SD	1-1/16	1-13/16	1/4	11.2	604B	11/16	A1	SD	1-5/16	1-13/16	3/4	13.3		
5.8	6.2	6.55	4.82	623B	7/16	A1	SD	1-1/16	1-13/16	1/4	12.6	624B	11/16	A1	SD	1-5/16	1-13/16	3/4	14.4		
6.0	6.4	6.75	5.06	643B	7/16	A1	SD	1-1/16	1-13/16	1/4	13.0	644B	11/16	A1	SD	1-5/16	1-13/16	3/4	15.1		
6.2	6.6	6.95	5.25	663B	7/16	A1	SD	1-1/16	1-13/16	1/4	10.5	664B	11/16	A1	SD	1-5/16	1-13/16	3/4	15.3		
6.4	6.8	7.15	5.44	683B	7/16	A2	SD	1-1/16	1-13/16	1/4	11.5	684B	11/16	A1	SD	1-5/16	1-13/16	3/4	16.8		
6.6	7.0	7.35	5.62	703B	1/32	D2	SK	11/16	1-7/8	21/32	15.2	704B	9/32	A1	SK	1	1-7/8	1-3/32	17.2		
7.0	7.4	7.75	6.06	743B	1/32	D2	SK	11/16	1-7/8	21/32	16.9	744B	9/32	A2	SK	1	1-7/8	1-3/32	16.2		
7.6	8.0	8.35	6.73	803B	1/32	D2	SK	11/16	1-7/8	21/32	15.7	804B	9/32	A2	SK	1	1-7/8	1-3/32	18.1		
8.2	8.6	8.95	7.31	863B	1/32	D2	SK	11/16	1-7/8	21/32	17.6	864B	9/32	A2	SK	1	1-7/8	1-3/32	22.0		
9.0	9.4	9.75	8.00	943B	1/32	D3	SK	11/16	1-7/8	21/32	18.0	944B	9/32	A2	SK	1	1-7/8	1-3/32	23.9		
10.6	11.0	11.35	9.62	1103B	1/32	D3	SK	11/16	1-7/8	21/32	19.6	1104B	9/32	A3	SK	1	1-7/8	1-3/32	26.4		
12.0	12.4	12.75	11.06	1243B	1/32	D3	SK	11/16	1-7/8	21/32	22.5	1244B	9/32	A3	SK	1	1-7/8	1-3/32	28.4		
13.2	13.6	13.95	12.25	1363B	1/32	D3	SK	11/16	1-7/8	21/32	26.4	1364B	9/32	A3	SK	1	1-7/8	1-3/32	29.9		
15.0	15.4	15.75	14.00	1543B	1/32	D3	SK	11/16	1-7/8	21/32	30.4	1544B	5/16	A3	SF	1	2	15/16	40.3		
15.6	16.0	16.35	14.62	1603B	1/32	D3	SK	11/16	1-7/8	21/32	32.7	1604B	5/16	A3	SF	1	2	15/16	38.7		
18.0	18.4	18.75	17.00	1843B	1/32	D3	SK	11/16	1-7/8	21/32	35.6	1844B	5/16	A3	SF	1	2	15/16	44.9		
19.6	20.0	20.35	18.50	2003B	1/16	D3	SF	5/8	2	9/16	45.7	2004B	5/16	A3	SF	1	2	15/16	56.6		
24.6	25.0	25.35	23.38	2503B	1/16	D3	SF	5/8	2	9/16	65.8	2504B	3/32	A3	E	1	2-5/8	17/32	83.2		
29.6	30.0	30.35	28.50	3003B	1/16	D3	SF	5/8	2	9/16	90.4	3004B	3/32	A3	E	1	2-5/8	17/32	110.1		
37.6	38.0	38.35	36.38	3803B	9/32	D3	E	5/8	2-5/8	5/32	143.3	3804B	3/32	A3	E	1	2-5/8	17/32	158.0		

\* "E" Dimension varies according to shaft tolerance.

Weights for all Sure-Grip bushed items are approximate and include the bushing.

 Also available from stock made for the SF Bushing to accommodate larger bores.

P.D. for "A" Belts = DD + .25

P.D. for "B" Belts = DD + .413

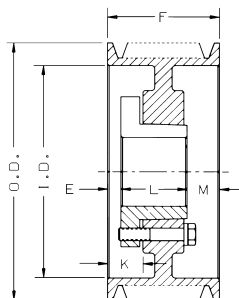

Type A

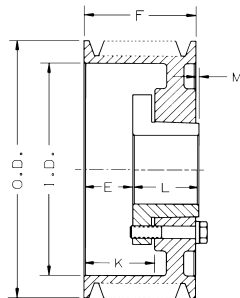

Type B

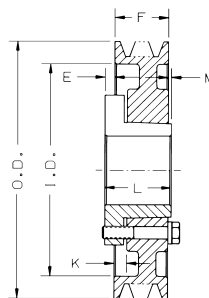

Type C

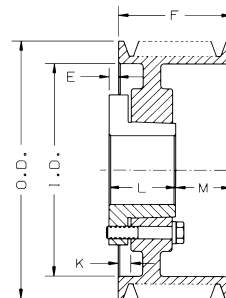

Type D

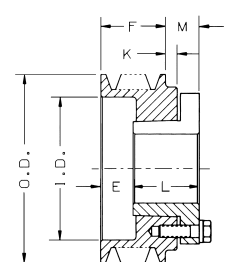

Type E

Sure-Grip Bushing dimensions — see section A1

These Classical Sheaves are designed to carry the loads of all belts shown in this catalog and other similarly rated V-Belts. For special higher rated V-Belts, consult Wood's Application Engineering Department for recommendations.

The sheaves listed below are all stock sizes. The dimensions given are with the Sure-Grip bushing in place. The figure following the letter in the "Type" column indicates the sheave construction: 1-Solid; 2-Web, 3-Arms.

**DIMENSIONS (In Inches)**

Datum Dia.		O.D.	I.D.	Product No.	5 GROOVE							Product No.	6 GROOVE						
A Belts	B Belts				F = 4								F = 4-3/4						
					E *	Type	Bush.	K	L	M	Wt.		E *	Type	Bush.	K	L	M	Wt.
3.0	3.4	3.75	2.12	345B	3-1/8	E1	SD	5/16	1-13/16	15/16	6.5	346B	3-7/8	E1	SD	5/16	1-13/16	15/16	7.2
3.2	3.6	3.95	2.25	365B	3-1/8	E1	SD	5/16	1-13/16	15/16	7.1	366B	3-7/8	E1	SD	5/16	1-13/16	15/16	8.0
3.4	3.8	4.15	2.44	385B	3-1/8	E1	SD	5/16	1-13/16	15/16	7.2	386B	3-7/8	E1	SD	5/16	1-13/16	15/16	8.1
3.6	4.0	4.35	2.62	405B	2-13/16	E1	SD	0	1-13/16	5/8	7.5	406B	3-9/16	E1	SD	0	1-13/16	5/8	8.5
3.8	4.2	4.55	2.88	425B	2-13/16	E1	SD	0	1-13/16	5/8	7.9	426B	3-9/16	E1	SD	0	1-13/16	5/8	9.0
4.0	4.4	4.75	3.12	445B	2-13/16	E1	SD	0	1-13/16	5/8	8.4	446B	3-9/16	E1	SD	0	1-13/16	5/8	9.5
4.2	4.6	4.95	3.31	465B	11/16	A1	SD	1-5/16	1-13/16	1-1/2	9.1	466B	11/16	A1	SD	1-5/16	1-13/16	2-1/4	10.2
4.4	4.8	5.15	3.44	485B	11/16	A1	SD	1-5/16	1-13/16	1-1/2	10.1	486B	11/16	A1	SD	1-5/16	1-13/16	2-1/4	11.0
4.6	5.0	5.35	3.62	505B	11/16	A1	SD	1-5/16	1-13/16	1-1/2	10.8	506B	11/16	A1	SD	1-5/16	1-13/16	2-1/4	11.8
4.8	5.2	5.55	3.81	525B	11/16	A1	SD	1-5/16	1-13/16	1-1/2	11.6	526B	11/16	A1	SD	1-5/16	1-13/16	2-1/4	13.0
5.0	5.4	5.75	4.12	545B	19/32	A1	SK	1-5/16	1-7/8	1-17/32	12.0	546B	19/32	A1	SK	1-5/16	1-7/8	2-9/32	13.3
5.2	5.6	5.95	4.30	565B	19/32	A1	SK	1-5/16	1-7/8	1-17/32	12.9	566B	19/32	A1	SK	1-5/16	1-7/8	2-9/32	14.6
5.4	5.8	6.15	4.48	585B	19/32	A1	SK	1-5/16	1-7/8	1-17/32	13.7	586B	19/32	A1	SK	1-5/16	1-7/8	2-9/32	15.5
5.6	6.0	6.35	4.68	605B	19/32	A1	SK	1-5/16	1-7/8	1-17/32	14.5	606B	19/32	A1	SK	1-5/16	1-7/8	2-9/32	16.5
5.8	6.2	6.55	4.82	625B	19/32	A1	SK	1-5/16	1-7/8	1-17/32	15.7	626B	19/32	A1	SK	1-5/16	1-7/8	2-9/32	17.4
6.0	6.4	6.75	5.06	645B	19/32	A1	SK	1-5/16	1-7/8	1-17/32	16.3	646B	19/32	A1	SK	1-5/16	1-7/8	2-9/32	18.0
6.2	6.6	6.95	5.29	665B	19/32	A1	SK	1-5/16	1-7/8	1-17/32	17.0	666B	19/32	A1	SK	1-5/16	1-7/8	2-9/32	18.7
6.4	6.8	7.15	5.44	685B	19/32	A1	SK	1-5/16	1-7/8	1-17/32	18.2	686B	19/32	A1	SK	1-5/16	1-7/8	2-9/32	20.1
6.6	7.0	7.35	5.63	705B	5/8	A1	SF	1-5/16	2	1-3/8	19.7	706B	1	A1	SF	1-11/16	2	1-3/4	21.7
7.0	7.4	7.75	6.06	745B	5/8	A1	SF	1-5/16	2	1-3/8	21.5	746B	1	A1	SF	1-11/16	2	1-3/4	23.6
7.6	8.0	8.35	6.63	805B	5/8	A1	SF	1-5/16	2	1-3/8	22.3	806B	1	A1	SF	1-11/16	2	1-3/4	27.1
8.2	8.6	8.95	7.31	865B	5/8	A2	SF	1-5/16	2	1-3/8	20.8	866B	1	A1	SF	1-11/16	2	1-3/4	30.2
9.0	9.4	9.75	8.00	945B	5/8	A3	SF	1-5/16	2	1-3/8	25.1	946B	1	A2	SF	1-11/16	2	1-3/4	25.7
10.6	11.0	11.35	9.62	1105B	5/8	A3	SF	1-5/16	2	1-3/8	31.0	1106B	1	A3	SF	1-11/16	2	1-3/4	36.0
12.0	12.4	12.75	11.06	1245B	5/8	A3	SF	1-5/16	2	1-3/8	34.0	1246B	1	A3	SF	1-11/16	2	1-3/4	37.5
13.2	13.6	13.95	12.31	1365B	5/8	A3	SF	1-5/16	2	1-3/8	36.7	1366B	1	A3	SF	1-11/16	2	1-3/4	41.7
15.0	15.4	15.75	14.06	1545B	5/8	A3	SF	1-5/16	2	1-3/8	42.3	1546B	1	A3	SF	1-11/16	2	1-3/4	46.1
15.6	16.0	16.35	14.62	1605B	5/8	A3	SF	1-5/16	2	1-3/8	47.1	1606B	1	A3	SF	1-11/16	2	1-3/4	51.8
18.0	18.4	18.75	17.00	1845B	5/8	A3	SF	1-5/16	2	1-3/8	54.8	1846B	1	A3	SF	1-11/16	2	1-3/4	60.7
19.6	20.0	20.35	18.56	2005B	11/32	A3	E	1-1/4	2-5/8	1-1/32	79.9	2006B	13/32	A3	E	1-3/8	2-5/8	1-21/32	78.3
24.6	25.0	25.35	23.38	2505B	11/32	A3	E	1-1/4	2-5/8	1-1/32	97.2	2506B	13/32	A3	E	1-3/8	2-5/8	1-21/32	116.8
29.6	30.0	30.35	28.50	3005B	11/32	A3	E	1-1/4	2-5/8	1-1/32	124.2	3006B	13/32	A3	E	1-3/8	2-5/8	1-21/32	144.5
37.6	38.0	38.35	36.38	3805B	11/32	A3	E	1-1/4	2-5/8	1-1/32	172.7	3806B	13/32	A3	E	1-3/8	2-5/8	1-21/32	189.9

\* "E" Dimension varies according to shaft tolerance.

Weights for all Sure-Grip bushed items are approximate and include the bushing.

P.D. for "A" Belts = DD + .25      P.D. for "B" Belts = DD + .413

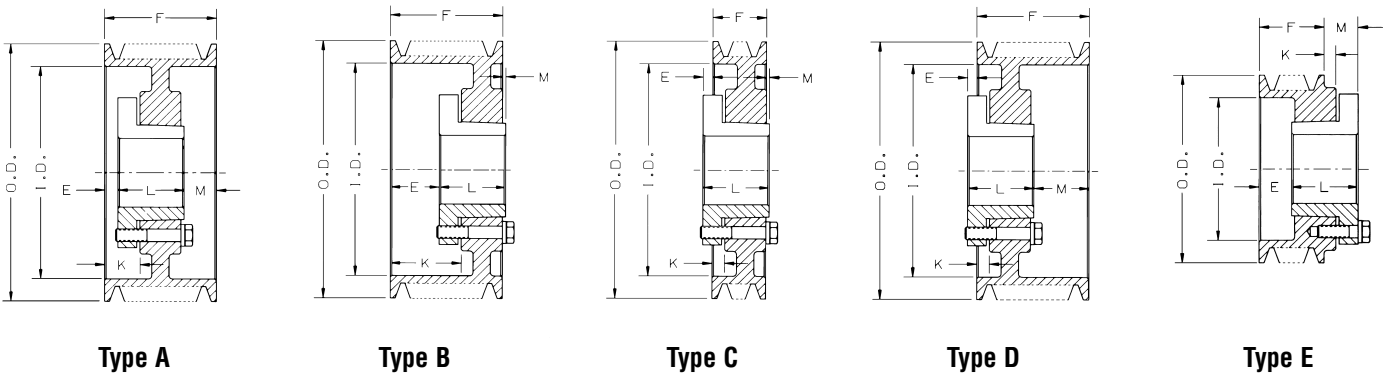

**Sure-Grip Bushing dimensions — see section A1**

# STOCK CLASSICAL (CONVENTIONAL) SHEAVES

# A-B



An Altra Industrial Motion Company

## DIMENSIONS (In Inches)

Datum Dia.		O.D.	I.D.	Product No.	7 GROOVE							Product No.	8 GROOVE						
A Belts	B Belts				F = 5-1/2								F = 6-1/4						
					E *	Type	Bush.	K	L	M	Wt.		E *	Type	Bush.	K	L	M	Wt.
5.0	5.4	5.75	4.12	547B	1-3/32	A1	SK	1-13/16	1-7/8	2-17/32	14.7	548B	1-3/32	A1	SK	1-13/16	1-7/8	3-9/32	16.0
5.2	5.6	5.95	4.25	567B	1-3/32	A1	SK	1-13/16	1-7/8	2-17/32	16.1	568B	1-3/32	A1	SK	1-13/16	1-7/8	3-9/32	20.6
5.4	5.8	6.15	4.44	587B	1-3/32	A1	SK	1-13/16	1-7/8	2-17/32	17.1	588B	1-3/32	A1	SK	1-13/16	1-7/8	3-9/32	18.7
5.6	6.0	6.35	4.68	607B	1-1/8	A1	SF	1-13/16	2	2-3/8	18.2	608B	1-1/8	A1	SF	1-13/16	2	3-1/8	19.7
5.8	6.2	6.55	4.81	627B	1-1/8	A1	SF	1-13/16	2	2-3/8	19.7	628B	1-1/8	A1	SF	1-13/16	2	3-1/8	21.5
6.0	6.4	6.75	5.06	647B	1-1/8	A1	SF	1-13/16	2	2-3/8	20.3	648B	1-1/8	A1	SF	1-13/16	2	3-1/8	22.0
6.2	6.6	6.95	5.25	667B	1-1/8	A1	SF	1-13/16	2	2-3/8	21.4	668B	1-1/8	A1	SF	1-13/16	2	3-1/8	23.2
6.4	6.8	7.15	5.44	687B	1-1/8	A1	SF	1-13/16	2	2-3/8	22.5	688B	1-1/8	A1	SF	1-13/16	2	3-1/8	24.4
6.6	7.0	7.35	5.62	707B	1-1/8	A1	SF	1-13/16	2	2-3/8	23.7	708B	1-1/8	A1	SF	1-13/16	2	3-1/8	25.7
7.0	7.4	7.75	6.06	747B	1-1/8	A1	SF	1-13/16	2	2-3/8	25.7	748B	1-1/8	A1	SF	1-13/16	2	3-1/8	27.7
8.2	8.6	8.95	7.25	867B	1-3/32	A1	E	2	2-5/8	1-25/32	38.4	868B	1-15/32	A1	E	2-3/8	2-5/8	2-5/32	40.9
9.0	9.4	9.75	8.06	947B	1-3/32	A2	E	2	2-5/8	1-25/32	39.6	948B	1-15/32	A2	E	2-3/8	2-5/8	2-5/32	42.4
10.6	11.0	11.35	9.62	1107B	1-3/32	A2	E	2	2-5/8	1-25/32	48.9	1108B	1-15/32	A2	E	2-3/8	2-5/8	2-5/32	52.2
12.0	12.4	12.75	11.04	1247B	1-3/32	A2	E	2	2-5/8	1-25/32	56.3	1248B	1-15/32	A2	E	2-3/8	2-5/8	2-5/32	59.5
13.2	13.6	13.95	12.25	1367B	1-3/32	A3	E	2	2-5/8	1-25/32	55.8	1368B	1-15/32	A3	E	2-3/8	2-5/8	2-5/32	59.8
15.0	15.4	15.75	14.00	1547B	1-3/32	A3	E	2	2-5/8	1-25/32	67.4	1548B	1-15/32	A3	E	2-3/8	2-5/8	2-5/32	70.8
15.6	16.0	16.35	14.62	1607B	1-3/32	A3	E	2	2-5/8	1-25/32	70.6	1608B	1-15/32	A3	E	2-3/8	2-5/8	2-5/32	73.9
18.0	18.4	18.75	16.75	1847B	1/4	A3	F	1-5/16	3-5/8	1-5/8	102.5	1848B	1/4	A3	F	1-5/16	3-5/8	2-3/8	111.7
19.6	20.0	20.35	18.56	2007B	1/4	A3	F	1-5/16	3-5/8	1-5/8	105.9	2008B	1/4	A3	F	1-5/16	3-5/8	2-3/8	113.4
24.6	25.0	25.35	23.38	2507B	1/4	A3	F	1-5/16	3-5/8	1-5/8	133.6	2508B	1/4	A3	F	1-5/16	3-5/8	2-3/8	145.9
29.6	30.0	30.35	28.38	3007B	1/4	A3	F	1-5/16	3-5/8	1-5/8	172.0	3008B	1/4	A3	F	1-5/16	3-5/8	2-3/8	183.0
37.6	38.0	38.35	36.38	3807B	1/4	A3	F	1-5/16	3-5/8	1-5/8	243.4	3808B	1/4	A3	F	1-5/16	3-5/8	2-3/8	246.9

Datum Dia.		O.D.	I.D.	Product No.	10 GROOVE						
A Belts	B Belts				F = 7-3/4						
					E *	Type	Bush.	K	L	M	Wt.
5.0	5.4	5.75	4.12	5410B	1-27/32	A1	SK	2-9/16	1-7/8	4-1/32	18.7
5.2	5.6	5.95	4.25	5610B	1-27/32	A1	SK	2-9/16	1-7/8	4-1/32	20.6
5.4	5.8	6.15	4.38	5810B	1-27/32	A1	SK	2-9/16	1-7/8	4-1/32	21.8
5.6	6.0	6.35	4.68	6010B	1-7/8	A1	SF	2-9/16	2	3-7/8	22.9
5.8	6.2	6.55	4.81	6210B	1-7/8	A1	SF	2-9/16	2	3-7/8	25.0
6.0	6.4	6.75	5.06	6410B	1-7/8	A1	SF	2-9/16	2	3-7/8	25.5
6.2	6.6	6.95	5.25	6610B	1-7/8	A1	SF	2-9/16	2	3-7/8	26.8
6.4	6.8	7.15	5.44	6810B	1-7/8	A1	SF	2-9/16	2	3-7/8	28.2
6.6	7.0	7.35	5.62	7010B	1-7/8	A1	SF	2-9/16	2	3-7/8	29.6
7.0	7.4	7.75	6.06	7410B	1-7/8	A1	SF	2-9/16	2	3-7/8	31.9
8.2	8.6	8.95	7.25	8610B	2-7/32	A1	E	3-1/8	2-5/8	2-29/32	45.8
9.0	9.4	9.75	8.12	9410B	2-7/32	A2	E	3-1/8	2-5/8	2-29/32	46.7
10.6	11.0	11.35	9.62	11010B	2-7/32	A2	E	3-1/8	2-5/8	2-29/32	58.8
12.0	12.4	12.75	11.06	12410B	2-7/32	A2	E	3-1/8	2-5/8	2-29/32	66.8
13.2	13.6	13.95	12.25	13610B	1	A3	F	2-1/16	3-5/8	3-1/8	83.6
15.0	15.4	15.75	14.00	15410B	1	A3	F	2-1/16	3-5/8	3-1/8	96.1
15.6	16.0	16.35	14.62	16010B	1	A3	F	2-1/16	3-5/8	3-1/8	99.8
18.0	18.4	18.75	16.75	18410B	1	A3	F	2-1/16	3-5/8	3-1/8	125.9
19.6	20.0	20.35	18.56	20010B	1	A3	F	2-1/16	3-5/8	3-1/8	126.6
24.6	25.0	25.35	23.44	25010B	1	A3	F	2-1/16	3-5/8	3-1/8	165.4
29.6	30.0	30.35	28.38	30010B	1	A3	F	2-1/16	3-5/8	3-1/8	220.0
37.6	38.0	38.35	36.38	38010B	5/16	A3	J	1-9/16	4-1/2	2-15/16	306.1

\* "E" Dimension varies according to shaft tolerance.  
 Weights for all Sure-Grip bushing items are approximate and include the bushing.  
 P.D. for "A" Belts = DD + .25  
 P.D. for "B" Belts = DD + .413

**Sure-Grip Bushing dimensions — see section A1**



# STOCK CLASSICAL (CONVENTIONAL) SHEAVES

# C

# TB Wood's Incorporated

An Altra Industrial Motion Company

## DIMENSIONS (In Inches)

Datum Dia.	O.D. ♦	I.D.	Product No.	5 GROOVE							Product No.	6 GROOVE						
				F = 5-3/8								F = 6-3/8						
				E *	Type	Bush.	K	L	M	Wt.		E *	Type	Bush.	K	L	M	Wt.
6.0	6.6	4.68	605C	1-5/16	A1	SF	1-15/16	2	2-1/16	15.5	606C	1-5/16	A1	SF	1-15/16	2	3-1/16	17.0
7.0	7.4	5.25	705C	1-1/4	A1	SF	1-15/16	2	2-1/8	23.8	706C	1-1/4	A1	SF	1-15/16	2	3-1/8	26.6
7.5	7.9	5.75	755C	1-1/4	A1	SF	1-15/16	2	2-1/8	26.6	756C	1-1/4	A1	SF	1-15/16	2	3-1/8	29.6
8.0	8.4	6.25	805C	1-15/32	A1	E	2-3/8	2-5/8	1-9/32	36.0	806C	1-15/32	A1	E	2-1/8	2-3/8	2-9/32	37.5
8.5	8.9	6.75	855C	1-15/32	A1	E	2-3/8	2-5/8	1-9/32	37.7	856C	1-15/32	A1	E	2-1/8	2-3/8	2-9/32	41.3
9.0	9.4	7.25	905C	1-15/32	A1	E	2-3/8	2-5/8	1-9/32	41.4	906C	1-3/8	A1	F	2-7/16	3-5/8	1-3/8	53.4
9.5	9.9	7.68	955C	1-15/32	A1	E	2-3/8	2-5/8	1-9/32	46.0	956C	1-3/8	A1	F	2-7/16	3-5/8	1-3/8	59.5
10.0	10.4	8.24	1005C	1-15/32	A1	E	2-3/8	2-5/8	1-9/32	49.3	1006C	1-3/8	A1	F	2-7/16	3-5/8	1-3/8	66.1
10.5	10.9	8.75	1055C	1-15/32	A2	E	2-3/8	2-5/8	1-9/32	47.8	1056C	1-3/8	A1	F	2-7/16	3-5/8	1-3/8	70.4
11.0	11.4	9.25	1105C	1-15/32	A2	E	2-3/8	2-5/8	1-9/32	50.0	1106C	1-3/8	A1	F	2-7/16	3-5/8	1-3/8	76.6
12.0	12.4	10.25	1205C	1-15/32	A2	E	2-3/8	2-5/8	1-9/32	55.7	1206C	1-3/8	A2	F	2-7/16	3-5/8	1-3/8	72.9
13.0	13.4	11.25	1305C	1-15/32	A2	E	2-3/8	2-5/8	1-9/32	62.0	1306C	1-3/8	A2	F	2-7/16	3-5/8	1-3/8	80.4
14.0	14.4	12.25	1405C	1-15/32	A3	E	2-3/8	2-5/8	1-9/32	64.1	1406C	1-3/8	A3	F	2-7/16	3-5/8	1-3/8	83.4
16.0	16.4	14.12	1605C	1-15/32	A3	E	2-3/8	2-5/8	1-9/32	78.1	1606C	1-3/8	A3	F	2-7/16	3-5/8	1-3/8	98.1
18.0	18.4	16.06	1805C	1-15/32	A3	E	2-3/8	2-5/8	1-9/32	92.9	1806C	1-3/8	A3	F	2-7/16	3-5/8	1-3/8	108.7
20.0	20.4	18.12	2005C	1/4	A3	F	1-5/16	3-5/8	1-1/2	109.5	2006C	7/8	A3	F	1-15/16	3-5/8	1-7/8	120.2
24.0	24.4	22.06	2405C	1/4	A3	F	1-5/16	3-5/8	1-1/2	141.0	2406C	7/8	A3	F	1-15/16	3-5/8	1-7/8	132.5
27.0	27.4	25.06	2705C	1/4	A3	F	1-5/16	3-5/8	1-1/2	159.0	2706C	5/16	A3	J	1-9/16	4-1/2	1-9/16	190.0
30.0	30.4	28.18	3005C	1/4	A3	F	1-5/16	3-5/8	1-1/2	171.2	3006C	5/16	A3	J	1-9/16	4-1/2	1-9/16	214.5
36.0	36.4	34.12	3605C	5/16	A3	J	1-9/16	4-1/2	9/16	236.3	3606C	5/16	A3	J	1-9/16	4-1/2	1-9/16	280.5
44.0	44.4	41.88	4405C	5/16	A3	J	1-9/16	4-1/2	9/16	309.2	4406C	5/16	A3	J	1-9/16	4-1/2	1-9/16	347.5
50.0	50.4	48.00	5005C	5/16	A3	J	1-9/16	4-1/2	9/16	381.8	5006C	15/32	B3	M	1-15/16	6-3/4	27/32	485.0

Datum Dia.	O.D. ♦	I.D.	Product No.	7 GROOVE							Product No.	8 GROOVE						
				F = 7-3/8								F = 8-3/8						
				E *	Type	Bush.	K	L	M	Wt.		E *	Type	Bush.	K	L	M	Wt.
7.0	7.4	5.25	707C	2-1/4	A1	SF	2-15/16	2	3-1/8	29.4	708C	2-7/16	A1	SF	3-1/8	2	3-15/16	32.2
8.0	8.4	6.25	807C	2-11/32	A1	E	3-1/4	2-5/8	2-13/32	40.9	808C	2-11/32	A1	E	3-1/4	2-5/8	3-13/32	44.2
8.5	8.9	6.75	857C	2-11/32	A1	E	3-1/4	2-5/8	2-13/32	44.8	858C	2-11/32	A1	E	3-1/4	2-5/8	3-13/32	48.4
9.0	9.4	7.25	907C	2-1/4	A1	F	3-5/16	3-5/8	1-1/2	57.1	908C	2-1/4	A1	F	3-5/16	3-5/8	2-1/2	60.9
9.5	9.9	7.68	957C	2-1/4	A1	F	3-5/16	3-5/8	1-1/2	63.7	958C	2-1/4	A1	F	3-5/16	3-5/8	2-1/2	68.0
10.0	10.4	8.24	1007C	2-1/4	A1	F	3-5/16	3-5/8	1-1/2	68.7	1008C	2-1/4	A1	F	3-5/16	3-5/8	2-1/2	75.1
10.5	10.9	8.75	1057C	2-1/4	A1	F	3-5/16	3-5/8	1-1/2	74.9	1058C	2-1/4	A1	F	3-5/16	3-5/8	2-1/2	79.4
11.0	11.4	9.25	1107C	2-1/4	A1	F	3-5/16	3-5/8	1-1/2	81.3	1108C	2-1/4	A1	F	3-5/16	3-5/8	2-1/2	86.0
12.0	12.4	10.25	1207C	2-1/4	A2	F	3-5/16	3-5/8	1-1/2	78.1	1208C	2-1/4	A2	F	3-5/16	3-5/8	2-1/2	83.3
13.0	13.4	11.25	1307C	2-1/4	A2	F	3-5/16	3-5/8	1-1/2	86.0	1308C	2-1/4	A2	F	3-5/16	3-5/8	2-1/2	91.7
14.0	14.4	12.25	1407C	2-1/4	A2	F	3-5/16	3-5/8	1-1/2	92.2	1408C	2-1/4	A2	F	3-5/16	3-5/8	2-1/2	100.8
16.0	16.4	14.12	1607C	2-1/4	A2	F	3-5/16	3-5/8	1-1/2	111.1	1608C	2-1/4	A2	F	3-5/16	3-5/8	2-1/2	119.0
18.0	18.4	16.06	1807C	2-1/4	A3	F	3-5/16	3-5/8	1-1/2	124.3	1808C	2-1/4	A3	F	3-5/16	3-5/8	2-1/2	133.7
20.0	20.4	18.12	2007C	5/16	A3	J	1-9/16	4-1/2	2-9/16	155.3	2008C	5/16	A3	J	1-9/16	4-1/2	3-9/16	162.0
24.0	24.4	22.06	2407C	5/16	A3	J	1-9/16	4-1/2	2-9/16	184.5	2408C	5/16	A3	J	1-9/16	4-1/2	3-9/16	189.4
27.0	27.4	25.06	2707C	5/16	A3	J	1-9/16	4-1/2	2-9/16	211.8	2708C	5/16	A3	J	1-9/16	4-1/2	3-9/16	242.3
30.0	30.4	28.18	3007C	5/16	A3	J	1-9/16	4-1/2	2-9/16	236.8	3008C	5/16	A3	J	1-9/16	4-1/2	3-9/16	256.0
36.0	36.4	34.12	3607C	5/16	A3	J	1-9/16	4-1/2	2-9/16	300.5	3608C	15/32	A3	M	1-15/16	6-3/4	1-5/32	406.0
44.0	44.4	41.97	4407C	15/32	A3	M	1-15/16	6-3/4	5/32	484.0	4408C	15/32	A3	M	1-15/16	6-3/4	1-5/32	510.0
50.0	50.4	48.00	5007C	15/32	A3	M	1-15/16	6-3/4	5/32	563.0	5008C	15/32	A3	M	1-15/16	6-3/4	1-5/32	565.0

\* "E" Dimension varies according to shaft tolerance.

Weights for all Sure-Grip bushed items are approximate and include the bushing.

♦ P.D. is same as O.D.

**Sure-Grip Bushing dimensions — see section A1**

### DIMENSIONS (In Inches)

Datum Dia.	O.D. ♦	I.D.	Product No.	9 GROOVE							Product No.	10 GROOVE						
				F = 9-3/8								F = 10-3/8						
				E *	Type	Bush.	K	L	M	Wt.		E *	Type	Bush.	K	L	M	Wt.
8.0	8.4	6.25	<b>809C</b>	2-11/32	A1	E	3-1/4	2-5/8	4-13/32	47.5	<b>8010C</b>	2-11/32	A1	E	3-1/4	2-5/8	5-13/32	50.8
8.5	8.9	6.75	<b>859C</b>	2-11/32	A1	E	3-1/4	2-5/8	4-13/32	51.9	<b>8510C</b>	2-11/32	A1	E	3-1/4	2-5/8	5-13/32	55.5
9.0	9.4	7.25	<b>909C</b>	2-5/16	A1	J	3-9/16	4-1/2	2-9/16	71.0	<b>9010C</b>	2-5/16	A1	J	3-9/16	4-1/2	3-9/16	74.5
9.5	9.9	7.68	<b>959C</b>	2-5/16	A1	J	3-9/16	4-1/2	2-9/16	79.6	<b>9510C</b>	2-5/16	A1	J	3-9/16	4-1/2	3-9/16	83.8
10.0	10.4	8.24	<b>1009C</b>	2-5/16	A1	J	3-9/16	4-1/2	2-9/16	85.9	<b>10010C</b>	2-5/16	A1	J	3-9/16	4-1/2	3-9/16	90.1
10.5	10.9	8.75	<b>1059C</b>	2-5/16	A1	J	3-9/16	4-1/2	2-9/16	93.7	<b>10510C</b>	2-5/16	A1	J	3-9/16	4-1/2	3-9/16	98.2
11.0	11.4	9.25	<b>1109C</b>	2-5/16	A1	J	3-9/16	4-1/2	2-9/16	101.9	<b>11010C</b>	2-5/16	A1	J	3-9/16	4-1/2	3-9/16	106.6
12.0	12.4	10.25	<b>1209C</b>	2-5/16	A1	J	3-9/16	4-1/2	2-9/16	119.1	<b>12010C</b>	2-5/16	A1	J	3-9/16	4-1/2	3-9/16	124.4
13.0	13.4	11.25	<b>1309C</b>	2-5/16	A2	J	3-9/16	4-1/2	2-9/16	111.9	<b>13010C</b>	2-5/16	A2	J	3-9/16	4-1/2	3-9/16	117.6
14.0	14.4	12.25	<b>1409C</b>	2-5/16	A2	J	3-9/16	4-1/2	2-9/16	120.5	<b>14010C</b>	2-5/16	A2	J	3-9/16	4-1/2	3-9/16	126.8
16.0	16.4	14.12	<b>1609C</b>	2-5/16	A2	J	3-9/16	4-1/2	2-9/16	146.2	<b>16010C</b>	2-5/16	A2	J	3-9/16	4-1/2	3-9/16	157.3
18.0	18.4	16.06	<b>1809C</b>	2-5/16	A3	J	3-9/16	4-1/2	2-9/16	155.3	<b>18010C</b>	2-5/16	A3	J	3-9/16	4-1/2	3-9/16	164.7
20.0	20.4	18.12	<b>2009C</b>	1-13/16	A3	J	3-1/16	4-1/2	3-1/16	175.2	<b>20010C</b>	2-5/16	A3	J	3-9/16	4-1/2	3-9/16	185.7
24.0	24.4	22.06	<b>2409C</b>	1-13/16	A3	J	3-1/16	4-1/2	3-1/16	207.7	<b>24010C</b>	15/32	A3	M	1-15/16	6-3/4	3-5/32	297.8
27.0	27.4	25.06	<b>2709C</b>	1-13/16	A3	J	3-1/16	4-1/2	3-1/16	242.8	...	...	...	...	...	...	...	...
30.0	30.4	28.18	<b>3009C</b>	15/32	A3	M	1-15/16	6-3/4	2-5/32	351.5	<b>30010C</b>	15/32	A3	M	1-15/16	6-3/4	3-5/32	366.8
36.0	36.4	34.12	<b>3609C</b>	15/32	A3	M	1-15/16	6-3/4	2-5/32	425.0	<b>36010C</b>	15/32	A3	M	1-15/16	6-3/4	3-5/32	445.0
44.0	44.4	42.12	<b>4409C</b>	15/32	A3	M	1-15/16	6-3/4	2-5/32	535.0	<b>44010C</b>	15/32	A3	M	1-15/16	6-3/4	3-5/32	595.0
50.0	50.4	48.00	<b>5009C</b>	15/32	A3	M	1-15/16	6-3/4	2-5/32	623.0	<b>50010C</b>	15/32	A3	M	1-15/16	6-3/4	3-5/32	718.0

Datum Dia.	O.D. ♦	I.D.	Product No.	12 GROOVE						
				F = 12-3/8						
				E *	Type	Bush.	K	L	M	Wt.
9.0	9.4	7.25	<b>9012C</b>	2-13/16	A1	J	4-1/16	4-1/2	5-1/16	81.5
9.5	9.9	7.68	<b>9512C</b>	2-13/16	A1	J	4-1/16	4-1/2	5-1/16	92.2
10.0	10.4	8.25	<b>10012C</b>	2-13/16	A1	J	4-1/16	4-1/2	5-1/16	98.6
10.5	10.9	8.75	<b>10512C</b>	2-13/16	A1	J	4-1/16	4-1/2	5-1/16	107.2
11.0	11.4	9.25	<b>11012C</b>	2-13/16	A1	J	4-1/16	4-1/2	5-1/16	116.1
12.0	12.4	10.25	<b>12012C</b>	2-13/16	A1	J	4-1/16	4-1/2	5-1/16	134.8
13.0	13.4	11.25	<b>13012C</b>	2-13/16	A1	J	4-1/16	4-1/2	5-1/16	159.5
14.0	14.4	12.25	<b>14012C</b>	2-13/16	A1	J	4-1/16	4-1/2	5-1/16	143.3
16.0	16.4	14.12	<b>16012C</b>	2-13/16	A2	J	4-1/16	4-1/2	5-1/16	169.5
18.0	18.4	16.06	<b>18012C</b>	2-13/16	A3	J	4-1/16	4-1/2	5-1/16	188.0
20.0	20.4	18.06	<b>20012C</b>	15/32	A3	M	1-15/16	6-3/4	5-5/32	292.1
24.0	24.4	22.18	<b>24012C</b>	15/32	A3	M	1-15/16	6-3/4	5-5/32	360.9
30.0	30.4	28.12	<b>30012C</b>	15/32	A3	M	1-15/16	6-3/4	5-5/32	397.4
36.0	36.4	34.12	<b>36012C</b>	15/32	A3	M	1-15/16	6-3/4	5-5/32	483.0
44.0	44.4	42.12	<b>44012C</b>	15/32	A3	M	1-15/16	6-3/4	5-5/32	645.0
50.0	50.4	48.00	<b>50012C</b>	15/32	A3	M	1-15/16	6-3/4	5-5/32	779.0

\* "E" Dimension varies according to shaft tolerance.  
 Weights for all Sure-Grip bushed items are approximate and include the bushing.  
 ♦ P.D. is same as O.D.

### Sure-Grip Bushing dimensions — see section A1

# CLASSICAL (Premium) V-BELT FEATURES



An Altra Industrial Motion Company

The Classical Premium V-belts include three cross sections . . . A, B, and C. These sections are a continuing development of the original V-belts of the 1930's. These belts are wrapped construction and are oil and heat resistant.

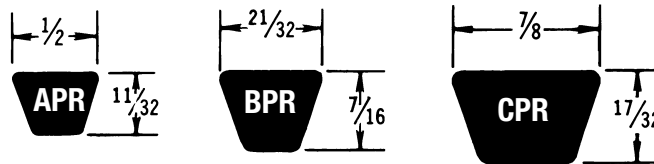

## All Premium-V Belts are constructed with :

### Kevlar\* or aramid tensile cords

Give extraordinary strength, durability and virtually zero stretch

### Specially-treated extra tough cover

Withstands slip and shear forces at peak loads without generating excessive heat; fends off penetration by foreign materials

### Heavy duty double fabric cover

Creates maximum abrasion resistance that protects against wear caused by fine airborne dust in rock quarries and lumber mills, which can cause rapid belt sidewall wear resulting in early failures

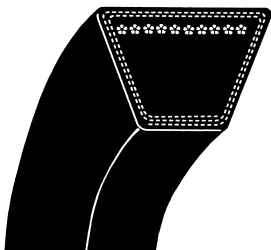

### Premium Single Belts

For applications when banded belts are not an option. Single belts can be used with deep groove sheaves and drives with limited room for "take up". They can also be an "A" section solution for multi-groove A/B sheaves.

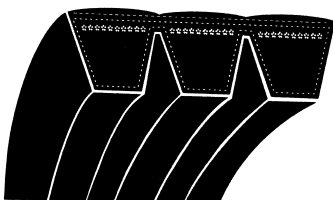

### Premium Banded Belts

Replaces several belts with the strength of a single belt. Banded belts feature a multiple layer tie band that provides excellent lateral rigidity to prevent belts from turning over or from coming off the drive

**Warning: When incorporating TB Wood's Premium-V belts, it is important to evaluate the load capacity of existing or specified sheaves. The exceptional strength of Premium-V belts, combined with tough application environments, require heavy-duty sheaves that can meet the challenge. TB Wood's offers a full array of sheaves manufactured in our foundry to meet stringent quality standards.**

\*Kevlar® is a registered trademark of Dupont™

**APR Single Belts**

Product No.	Belt Length*	Weight
APR31	33	0.24
APR33	35	0.26
APR35	37	0.27
APR38	40	0.29
APR40	42	0.31
APR42	44	0.32
APR43	45	0.33
APR44	46	0.34
APR45	47	0.35
APR46	48	0.35
APR47	49	0.36
APR48	50	0.37
APR50	52	0.38
APR51	53	0.39
APR52	54	0.40
APR53	55	0.40
APR54	56	0.41
APR55	57	0.42
APR56	58	0.43
APR58	60	0.44

Product No.	Belt Length*	Weight
APR59	61	0.45
APR60	62	0.46
APR61	63	0.46
APR62	64	0.47
APR63	65	0.48
APR64	66	0.48
APR66	68	0.50
APR68	70	0.51
APR70	72	0.53
APR71	73	0.54
APR85	87	0.64
APR87	89	0.65
APR90	92	0.68
APR91	93	0.68

**BPR Single Belts**

Product No.	Belt Length*	Weight
BPR32	35	0.39
BPR38	41	0.46
BPR40	43	0.48
BPR42	45	0.50
BPR44	47	0.53
BPR46	49	0.55
BPR48	51	0.57
BPR50	53	0.59
BPR51	54	0.61
BPR52	55	0.62
BPR53	56	0.63
BPR54	57	0.64
BPR55	58	0.65
BPR56	59	0.66
BPR57	60	0.67
BPR58	61	0.68
BPR59	62	0.69
BPR60	63	0.71
BPR61	64	0.72
BPR62	65	0.73
BPR63	66	0.74
BPR64	67	0.75
BPR65	68	0.76
BPR66	69	0.77
BPR68	71	0.80

Product No.	Belt Length*	Weight
BPR70	73	0.82
BPR71	74	0.83
BPR75	78	0.87
BPR78	81	0.91
BPR80	83	0.93
BPR81	84	0.94
BPR83	86	0.96
BPR85	88	0.99
BPR90	93	1.04
BPR93	96	1.08
BPR95	98	1.10
BPR97	100	1.12
BPR100	103	1.15
BPR103	106	1.19
BPR105	108	1.21
BPR108	111	1.24
BPR112	115	1.29
BPR120	123	1.38
BPR124	127	1.42
BPR128	131	1.47
BPR136	139	1.56
BPR144	147	1.65
BPR158	161	1.80
BPR173	176	1.97
BPR195	198	2.22

**CPR Single Belts**

Product No.	Belt Length*	Weight
CPR85	89	1.86
CPR90	94	1.96
CPR96	100	2.09
CPR99	103	2.15
CPR100	104	2.17
CPR105	109	2.27
CPR112	116	2.42
CPR120	124	2.59
CPR128	132	2.75
CPR136	140	2.92
CPR144	148	3.09
CPR158	162	3.38
CPR162	166	3.46
CPR173	177	3.69
CPR180	184	3.84
CPR195	199	4.15
CPR240	242	5.05

**CPR Banded Belts**

Product No.	Belt Length*	Weight
3/CPR85	85	5.85
3/CPR90	90	6.17
3/CPR99	99	6.77
4/CPR240	242	21.19
4/CPR330	332	29.08
4/CPR345	347	30.39
4/CPR360	362	31.70
5/CPR195	199	21.79
5/CPR225	227	24.85
5/CPR255	257	28.13

\* Belt length = the outside circumference (in.)



# DRIVE SELECTION – CLASSICAL BELTS



An Altra Industrial Motion Company

## 1. Determine DESIGN HORSEPOWER

DESIGN HORSEPOWER = DriveR HP x Service Factor (See below)

## SERVICE FACTORS

DRIVEN MACHINE See Note 1	DRIVER					
	AC Normal Torque Electric Motor (NEMA Design A-B) See Note 2			AC High Torque Electric Motor (NEMA Design C-D) See Note 3		
	Intermittent Service See Note 4	Normal Service See Note 5	Continuous Service See Note 6	Intermittent Service See Note 4	Normal Service See Note 5	Continuous Service See Note 6
Agitators for Liquids . . . . .	1.0	1.1	1.2	1.1	1.2	1.3
Blowers and Exhausters . . . . .						
Centrifugal Pumps and Compressors . . . . .						
Conveyors (Light Duty). . . . .						
Fans (up to 10 H.P.) . . . . .	1.1	1.2	1.3	1.2	1.3	1.4
Belt Conveyors for Sand, Grain, etc. . . . .						
Fans (over 10 H.P.) . . . . .						
Generators. . . . .						
Laundry Machinery . . . . .						
Line Shafts . . . . .						
Machine Tools . . . . .						
Mixers (Dough). . . . .						
Positive Displacement Rotary Pumps. . . . .						
Printing Machinery . . . . .						
Punches-Presses-Shears See Note 1 . . . . .						
Revolving and Vibrating Screens . . . . .	1.2	1.3	1.4	1.4	1.5	1.6
Blowers (Positive Displacement). . . . .						
Brick Machinery . . . . .						
Compressors (Piston) See Note 1 . . . . .						
Conveyors (Drag-Pan-Screw) . . . . .						
Elevators (Bucket). . . . .						
Exciters . . . . .						
Hammer Mills . . . . .						
Paper Mill Beaters. . . . .						
Pulverizers. . . . .						
Pumps (Piston). . . . .						
Saw Mill and Woodworking Machinery. . . . .						
Textile Machinery . . . . .						
Crushers (Gyratory-Jaw-Roll) See Note 1. . . . .						
Mills (Ball-Rod-Tube) See Note 1 . . . . .						
Hoists See Note 1 . . . . .						
Rubber Calenders-Extruders-Mills See Note 1						

**Note 1** The Driven Machines listed above are representative samples only. When one of the sheaves of the drive is used as a flywheel to reduce speed fluctuations and equalize the energy exerted at the shaft or for applications involving impact or jam loads, specially constructed sheaves may be required. Consult the manufacturer.

**Note 2** Included under this heading are the following electric motors: Synchronous and Squirrel Cage AC Normal Torque, AC Split Phase, DC Shunt Wound and Internal Combustion Engines.

**Note 3** Included under this heading are the following electric motors: AC High Torque, AC Hi-Slip, AC Repulsion, Induction, AC Single Phase Series Wound, AC Slip Ring and DC Compound Wound.

**Note 4** Intermittent Service refers to 3–5 hours of daily or seasonal operation.

**Note 5** Normal Service indicates 8–10 hours of daily operation.

**Note 6** Continuous Service refers to 16–24 hours of daily operation.

**Note 7** If idlers are used, add the following to the service factor.

Idler on slack side (inside)	None
Idler on slack side (outside)	0.1
Idler on tight side (inside)	0.1
Idler on tight side (outside)	0.2

2. Select **BELT CROSS SECTION** using chart below.

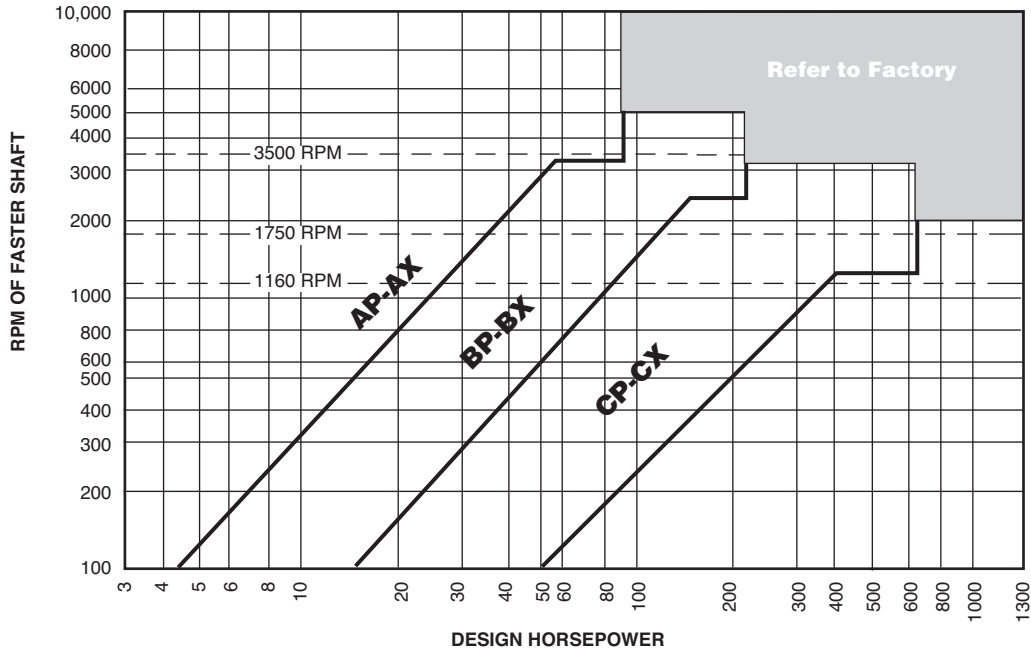

3. If using a 60 HZ electric motor, **Note the Minimum Motor Sheave Outside Diameter recommended by NEMA.**

Motor Horsepower	MOTOR RPM			
	870	1160	1750	3500
1/2	2.2	...	...	...
3/4	2.4	2.2	...	...
1	2.4	2.4	2.2	...
1-1/2	2.4	2.4	2.4	2.2
2	3.0	2.4	2.4	2.4
3	3.0	3.0	2.4	2.4
5	3.8	3.0	3.0	2.4
7-1/2	4.4	3.8	3.0	3.0
10	4.4	4.4	3.8	3.0
15	5.2	4.4	4.4	3.8
20	6.0	5.2	4.4	4.4
25	6.8	6.0	4.4	4.4
30	6.8	6.8	5.2	...
40	8.2	6.8	6.0	...
50	8.4	8.2	6.8	...
60	10.0	8.2	7.4	...
75	10.0	10.0	8.6	...
100	12.0	10.0	8.6	...
125	...	12.0	10.5	...
150	...	...	10.5	...
200	...	...	13.2	...
250	...	...	...	...
300	...	...	...	...

# DRIVE SELECTION – CLASSICAL BELTS



An Altra Industrial Motion Company

- BELT LENGTH =  $2 \times C + 1.57 \times (D + d) + [(D - d)^2 / (4 \times C)]$
- CENTER DISTANCE =  $1/2 \times [A - h \times (D - d)]$

WHERE:

C = Center Distance (in.)      D = Datum Diameter of larger sheave (in.)  
 L = Belt Datum Length (in.)      d = Datum Diameter of smaller sheave (in.)  
 A =  $L - 1.57 \times (D + d)$       h = Factor from chart below

D - d A	h	D - d A	h	D - d A	h	D - d A	h
0.00	0.00	0.16	0.08	0.30	0.16	0.43	0.24
0.02	0.01	0.18	0.09	0.32	0.17	0.44	0.25
0.04	0.02	0.20	0.10	0.34	0.18	0.46	0.26
0.06	0.03	0.21	0.11	0.35	0.19	0.47	0.27
0.08	0.04	0.23	0.12	0.37	0.20	0.48	0.28
0.10	0.05	0.25	0.13	0.39	0.21	0.50	0.29
0.12	0.06	0.27	0.14	0.40	0.22	0.51	0.30
0.14	0.07	0.29	0.15	0.41	0.23	...	...

## AC FACTORS

D - d C	Factor Ac	D - d C	Factor Ac
0.000	1.000	0.750	0.879
0.025	0.997	0.775	0.874
0.050	0.994	0.800	0.869
0.075	0.990	0.825	0.864
0.100	0.987	0.850	0.858
0.125	0.983	0.875	0.852
0.150	0.980	0.900	0.847
0.175	0.977	0.925	0.841
0.200	0.973	0.950	0.835
0.225	0.969	0.975	0.829
0.250	0.966	1.000	0.823
0.275	0.962	1.025	0.816
0.300	0.958	1.050	0.810
0.325	0.954	1.075	0.803
0.350	0.951	1.100	0.796
0.375	0.947	1.125	0.789
0.400	0.943	1.150	0.782
0.425	0.939	1.175	0.774
0.450	0.935	1.200	0.767
0.475	0.930	1.225	0.759
0.500	0.926	1.250	0.751
0.525	0.922	1.275	0.742
0.550	0.917	1.300	0.734
0.575	0.913	1.325	0.725
0.600	0.908	1.350	0.716
0.625	0.904	1.375	0.706
0.650	0.899	1.400	0.697
0.675	0.894	1.425	0.687
0.700	0.889		
0.725	0.884		

## LC FACTORS

Belt No.	Correction Factor Lc	Belt No.	Correction Factor Lc	Belt No.	Correction Factor Lc
APR31	.84	BPR35	.81	CPR85	.90
APR35	.87	BPR38	.83	CPR90	.91
APR38	.88	BPR42	.85	CPR96	.92
APR42	.90	BPR46	.87	CPR105	.94
		BPR51	.89	CPR112	.95
APR46	.92				
APR51	.94	BPR55	.90	CPR120	.97
APR55	.96	BPR60	.92	CPR128	.98
APR60	.98	BPR68	.95	CPR136	.99
APR68	1.00	BPR75	.97	CPR144	1.00
		BPR81	.98	CPR158	1.02
APR75	1.02				
APR80	1.04	BPR85	.99	CPR162	1.03
APR85	1.05	BPR90	1.00	CPR173	1.04
APR90	1.06	BPR97	1.02	CPR180	1.05
APR96	1.08	BPR105	1.04	CPR195	1.07
		BPR112	1.05	CPR210	1.08
APR105	1.10				
APR112	1.11	BPR120	1.07	CPR240	1.11
APR120	1.13	BPR128	1.08	CPR270	1.14
APR128	1.14	BPR136	1.09	CPR300	1.16
		BPR144	1.11	CPR360	1.21
		BPR158	1.13	CPR390	1.23
		BPR173	1.15	CPR420	1.24
		BPR180	1.16		
		BPR195	1.18		
		BPR210	1.19		
		BPR240	1.22		
		BPR270	1.25		
		BPR300	1.27		

Proper balance of rotating products is important for smooth, vibration-free operation. Standard balance of Wood's stock products is a one plane balance. Depending on the face width, outside diameter, and operating speed a higher precision balance may be required for smooth operation. In those cases a two-plane balance is suggested.

**Note: Two plane balance is for smooth operation only and DOES NOT increase the maximum safe operating speed of the product. Stock cast iron wheels may not exceed 6,550 feet per minute; and ductile iron wheels are limited to 10,000 FPM. (FPM = sheave outside diameter x RPM x .262)**

The nomograph below may be used as a guideline to determine when two-plane balance is recommended. To use this chart lay a straight-edge between the diameter of the part on the left of the chart and the face width of the part on the right. The straight edge will intersect the slanted scale in the center of the chart. When the operating speed is greater than the intersection point a two-plane balance is recommended.

**Example:** If a 20 in. diameter x 10 in. face width sheave runs faster than 1100 rpm, dynamic balancing is recommended.

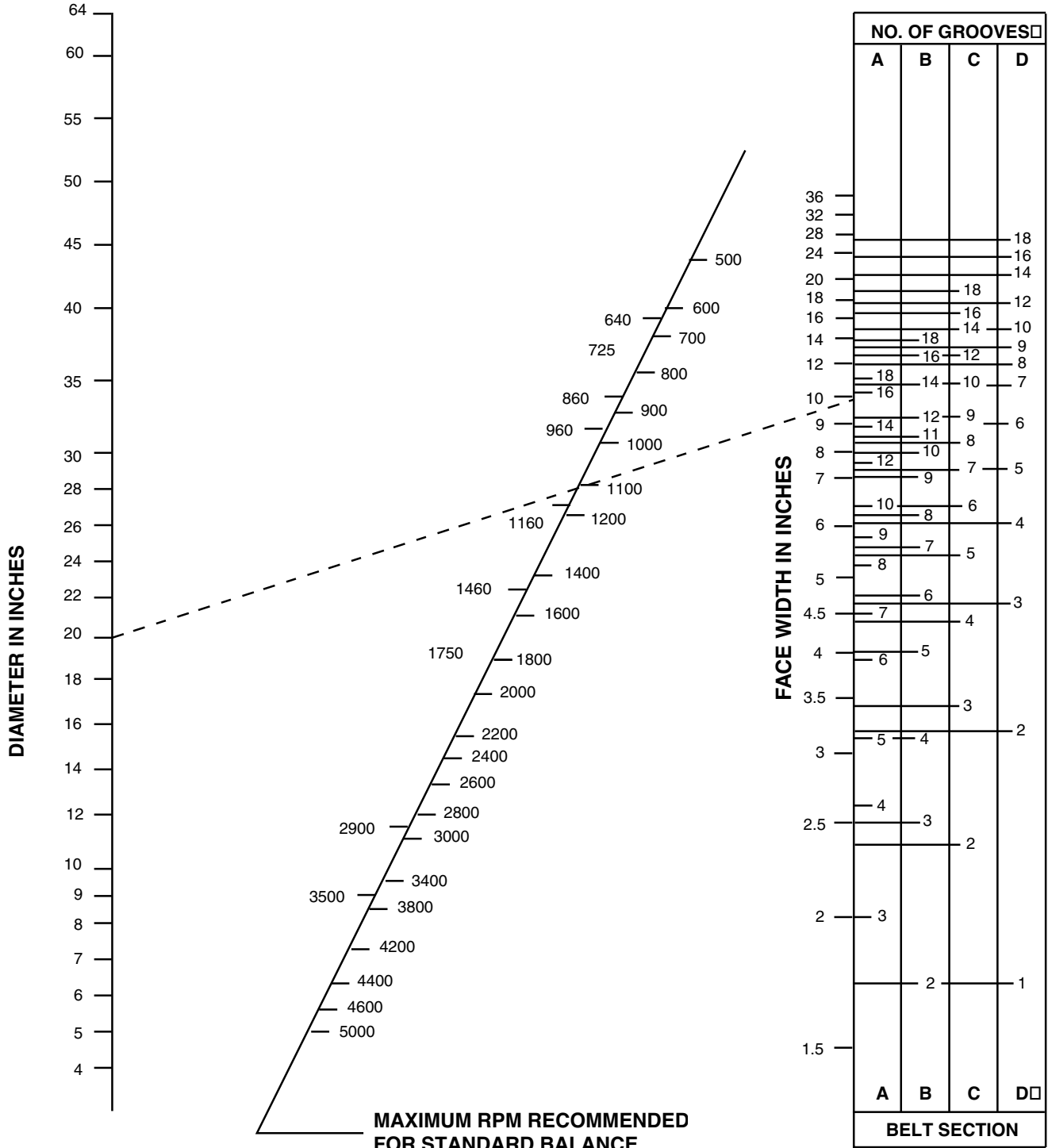

# DRIVE SELECTION CLASSICAL BELTS

Example: A 60 HP 1780 RPM NEMA C motor driving a machine tool operating at 1250 RPM, 24 hours per day. The motor shaft is 2-3/8" diameter, the machine tool is supplied with a 12.75 x 3B sheave mounted and the center distance is 32".

Procedure		Example										
<b>Step #1</b>	<b>Calculate the Design Horsepower</b> DHP=DriveR HP x service Factor (page BP2-13)	Service Factor = 1.4 DHP = 60 x 1.4 = 84										
<b>Step #2</b>	<b>Choose the Belt Cross Section</b> Reference chart (page BP2-14)	84 DHP and 1780 RPM intersect in the BP section.										
<b>Step #3</b>	<b>Check NEMA recommended Minimum Motor Sheave Outside Diameter</b> (page BP2-14)	Minimum O.D. for a 60 HP, 1780 RPM motor is 7.4 inches										
<b>Step #4</b>	<b>Calculate Speed Ratio</b> Speed Ratio = Faster RPM/Slower RPM	Speed Ratio = 1780 RPM / 1250 RPM = 1.42										
<b>Step #5</b>	<b>Use the Ratio and any diameter limits or known sheaves to determine the diameters of DriveR and DriveN. Try to utilize stock parts when possible.</b>	12.75 OD Known DriveN Sheave = 12.4 PD 12.4 PD DriveN Sheave / 1.42 Ratio = 8.73 PD DriveR Sheave Use Stock 86B stock sheave = 8.6 PD										
<b>Step #6</b>	<b>Using the diameter of the sheave the actual ratio and speed can be calculated.</b>	Actual Ratio = 12.4 DriveN / 8.6 DriveR = 1.44 Actual RPM = 1780 RPM DriveR / 1.44 = 1236 RPM DriveN										
<b>Step #7</b>	<b>Calculate Belt Length to determine the closest stock belt. Then calculate the actual CD using the stock belt.</b> (Formulas on page BP2-15)	$BL = 2 \times 32 + 1.57 \times (12.4 + 8.6) + [(12.4 - 8.6)^2 / (4 \times 32)]$ BL = 97.1 – Use a BP95 Belt A = 96.8 – 1.57 x (12.4 + 8.6) = 63.8 CD = 1/2 x [63.8 - .03 x (12.4 – 8.6)] = 31.84"										
<b>Step #8</b>	<b>Find the AC and LC correction factors.</b> (Page BP2-15)	AC factor = .985 LC factor for BP95 belts = 1.01										
<b>Step #9</b>	<b>In the HP Rating Tables, following the Drive Selection Tables, locate the HP per Belt under the correct Belt Section.</b> (Use Small Sheave Diameter and RPM)	BP rating tables (Page BP2-18 to BP2-22) 8.6 diameter @ 1780 RPM HP / Belt = 30.0										
<b>Step #10</b>	<b>Calculate corrected HP per Belt</b> Add on for ratio is found to the right of the HP Rating Tables CHP = (HP per Belt + Add on) x AC x LC	Add on for 1.44 ratio = 1.21 CHP = (30.0 + 1.21) x .985 x 1.01 = 31.05										
<b>Step #11</b>	<b>Determine the number of belts required</b> NOB = Design HP/CHP	NOB = 84 DHP / 31.05 CHP = 2.71 Use 3 belts										
<b>Step #12</b>	<b>Check for Dynamic Balance Recommendations</b> Reference Chart (page BP2-16)	OK as Standard – 8.6 x 3B standard balance good to 3800 RPM OK as Standard – 12.4 x 3B standard balance good to 3000 RPM										
<b>Step #13</b>	<b>Stock cast iron parts are good to 6500 FPM.</b> If operating faster MTO ductile iron is required. FPM = diameter (in.) x RPM x .262	FPM = 8.95 x 1780 x .262 = 4174 FPM Standard Cast Iron parts are OK.										
<b>Step #14</b>	<b>Specify Drive Components</b> Reference Component Dimensional pages for Product Number	<table border="0"> <thead> <tr> <th>Item</th> <th>Product No.</th> </tr> </thead> <tbody> <tr> <td>DR – 8.6 x 3B sheave</td> <td>863B</td> </tr> <tr> <td>- SK Bushing for 2-3/8" bore</td> <td>SK238</td> </tr> <tr> <td>DN – Existing 12.4 x 3B sheave</td> <td></td> </tr> <tr> <td>Belts – Qty. of 3 Belts</td> <td>BPR95</td> </tr> </tbody> </table>	Item	Product No.	DR – 8.6 x 3B sheave	863B	- SK Bushing for 2-3/8" bore	SK238	DN – Existing 12.4 x 3B sheave		Belts – Qty. of 3 Belts	BPR95
Item	Product No.											
DR – 8.6 x 3B sheave	863B											
- SK Bushing for 2-3/8" bore	SK238											
DN – Existing 12.4 x 3B sheave												
Belts – Qty. of 3 Belts	BPR95											

Classical horsepower ratings per belt are listed below and on the facing page. To obtain the basic horsepower rating per belt, locate the rpm of the faster shaft in the left-hand column. Read on this line across to the column headed by the diameter of the smaller sheave. The figure given is the basic horsepower rating. For convenience the standard motor speeds are grouped at the beginning of the chart. On the same horizontal line read the "add-on" rating in the column headed by the drive speed ratio. Add the basic rating to the "add-on" rating to obtain the total horsepower rating per belt.

### Rated Horsepower per belt - For A Section Premium Belts

RPM of Faster Shaft	Basic Horsepower per Belt														
	Small Sheave Datum Diameter														
	3.00	3.20	3.40	3.60	3.80	4.00	4.20	4.60	4.80	5.00	5.20	5.60	6.00	6.40	7.00
1160	2.24	2.69	3.12	3.56	4.00	4.43	4.86	5.71	6.14	6.56	6.98	7.82	8.65	9.47	10.7
1425	2.62	3.15	3.68	4.21	4.73	5.25	5.77	6.79	7.30	7.81	8.31	9.31	10.3	11.3	12.7
1750	3.04	3.68	4.32	4.95	5.57	6.20	6.82	8.04	8.65	9.25	9.85	11.0	12.2	13.4	15.1
2850	4.19	5.16	6.12	7.07	8.01	8.93	9.85	11.6	12.5	13.4	14.3	15.9	17.5	19.1	21.3
3450	4.63	5.76	6.87	7.97	9.05	10.1	11.1	13.2	14.2	15.1	16.1	17.9	19.6	21.2	
200	0.54	0.63	0.71	0.80	0.88	0.97	1.05	1.22	1.31	1.39	1.47	1.64	1.81	1.97	2.22
400	0.96	1.13	1.29	1.46	1.62	1.78	1.94	2.26	2.42	2.58	2.74	3.06	3.38	3.69	4.16
600	1.34	1.58	1.82	2.06	2.29	2.53	2.76	3.23	3.47	3.70	3.93	4.39	4.85	5.31	5.99
800	1.68	2.00	2.31	2.62	2.93	3.24	3.54	4.15	4.46	4.76	5.06	5.66	6.26	6.85	7.73
1000	2.00	2.39	2.77	3.15	3.53	3.91	4.29	5.04	5.41	5.78	6.15	6.88	7.61	8.33	9.41
1200	2.30	2.76	3.21	3.66	4.11	4.56	5.00	5.88	6.32	6.75	7.19	8.05	8.90	9.75	11.0
1400	2.59	3.11	3.63	4.15	4.66	5.17	5.68	6.69	7.20	7.69	8.19	9.18	10.2	11.1	12.5
1600	2.85	3.44	4.03	4.61	5.19	5.77	6.34	7.48	8.04	8.60	9.15	10.3	11.3	12.4	14.0
1800	3.10	3.76	4.41	5.06	5.70	6.34	6.97	8.23	8.85	9.46	10.1	11.3	12.5	13.7	15.4
2000	3.34	4.06	4.77	5.48	6.18	6.88	7.58	8.95	9.62	10.3	11.0	12.3	13.6	14.8	16.7
2200	3.56	4.34	5.12	5.89	6.65	7.40	8.15	9.63	10.4	11.1	11.8	13.2	14.6	16.0	17.9
2400	3.77	4.61	5.45	6.27	7.09	7.90	8.71	10.3	11.1	11.8	12.6	14.1	15.6	17.0	19.1
2600	3.96	4.86	5.76	6.64	7.51	8.38	9.23	10.9	11.7	12.6	13.4	14.9	16.5	18.0	20.1
2800	4.14	5.10	6.05	6.98	7.91	8.83	9.73	11.5	12.4	13.2	14.1	15.7	17.3	18.9	21.1
3000	4.31	5.32	6.32	7.31	8.29	9.25	10.2	12.1	13.0	13.9	14.7	16.5	18.1	19.7	22.0
3200	4.46	5.53	6.58	7.62	8.64	9.65	10.6	12.6	13.5	14.5	15.4	17.1	18.8	20.4	22.7
3400	4.60	5.72	6.82	7.90	8.97	10.0	11.1	13.1	14.0	15.0	15.9	17.7	19.5	21.1	
3600	4.72	5.89	7.04	8.16	9.27	10.4	11.4	13.5	14.5	15.5	16.4	18.3	20.0		
3800	4.83	6.04	7.23	8.40	9.55	10.7	11.8	13.9	14.9	15.9	16.9	18.8			
4000	4.93	6.18	7.41	8.62	9.80	11.0	12.1	14.3	15.3	16.3	17.3				
4200	5.00	6.30	7.57	8.82	10.0	11.2	12.4	14.6	15.6	16.7					
4400	5.07	6.40	7.71	8.99	10.2	11.4	12.6	14.9	15.9						
4600	5.11	6.49	7.83	9.13	10.4	11.6	12.8	15.1							
4800	5.14	6.55	7.92	9.25	10.5	11.8	13.0								
5000	5.16	6.59	7.99	9.34	10.7	11.9	13.1								

\* Made-to-order ductile iron sheaves required.

# HORSEPOWER RATINGS for APR BELTS



An Altra Industrial Motion Company

The combined Arc-Length correction factor shown in the Classical pre-engineered drive tables or in the Arc-of-Contact correction factor table and the Belt Length correction factor table, page B2-15, should be applied to the total hp per belt before determining the number of belts required for the drive.

RPM of Faster Shaft	"Add-on" Horsepower rating per Belt									
	Speed Ratio									
	1.00	1.02	1.03	1.05	1.06	1.08	1.10	1.14	1.20	1.29
	1.01	1.02	1.04	1.05	1.07	1.10	1.13	1.19	1.28	over
1160	0.00	0.03	0.07	0.10	0.14	0.17	0.20	0.24	0.27	0.30
1425	0.00	0.04	0.08	0.12	0.17	0.21	0.25	0.29	0.33	0.37
1750	0.00	0.05	0.10	0.15	0.20	0.25	0.31	0.36	0.41	0.46
2850	0.00	0.08	0.17	0.25	0.33	0.41	0.50	0.58	0.66	0.75
3450	0.00	0.10	0.20	0.30	0.40	0.50	0.60	0.70	0.80	0.90
200	0.00	0.01	0.01	0.02	0.02	0.03	0.03	0.04	0.05	0.05
400	0.00	0.01	0.02	0.03	0.05	0.06	0.07	0.08	0.09	0.10
600	0.00	0.02	0.03	0.05	0.07	0.09	0.10	0.12	0.14	0.16
800	0.00	0.02	0.05	0.07	0.09	0.12	0.14	0.16	0.19	0.21
1000	0.00	0.03	0.06	0.09	0.12	0.15	0.17	0.20	0.23	0.26
1200	0.00	0.03	0.07	0.10	0.14	0.17	0.21	0.24	0.28	0.31
1400	0.00	0.04	0.08	0.12	0.16	0.20	0.24	0.29	0.33	0.37
1600	0.00	0.05	0.09	0.14	0.19	0.23	0.28	0.33	0.37	0.42
1800	0.00	0.05	0.10	0.16	0.21	0.26	0.31	0.37	0.42	0.47
2000	0.00	0.06	0.12	0.17	0.23	0.29	0.35	0.41	0.47	0.52
2200	0.00	0.06	0.13	0.19	0.26	0.32	0.38	0.45	0.51	0.58
2400	0.00	0.07	0.14	0.21	0.28	0.35	0.42	0.49	0.56	0.63
2600	0.00	0.08	0.15	0.23	0.30	0.38	0.45	0.53	0.61	0.68
2800	0.00	0.08	0.16	0.24	0.33	0.41	0.49	0.57	0.65	0.73
3000	0.00	0.09	0.17	0.26	0.35	0.44	0.52	0.61	0.70	0.79
3200	0.00	0.09	0.19	0.28	0.37	0.47	0.56	0.65	0.74	0.84
3400	0.00	0.10	0.20	0.30	0.40	0.49	0.59	0.69	0.79	0.89
3600	0.00	0.10	0.21	0.31	0.42	0.52	0.63	0.73	0.84	0.94
3800	0.00	0.11	0.22	0.33	0.44	0.55	0.66	0.77	0.88	1.00
4000	0.00	0.12	0.23	0.35	0.47	0.58	0.70	0.81	0.93	1.05
4200	0.00	0.12	0.24	0.37	0.49	0.61	0.73	0.86	0.98	1.10
4400	0.00	0.13	0.26	0.38	0.51	0.64	0.77	0.90	1.02	1.15
4600	0.00	0.13	0.27	0.40	0.54	0.67	0.80	0.94	1.07	1.21
4800	0.00	0.14	0.28	0.42	0.56	0.70	0.84	0.98	1.12	1.26
5000	0.00	0.15	0.29	0.44	0.58	0.73	0.87	1.02	1.16	1.31

Classical horsepower ratings per belt are listed below and on the facing page. To obtain the basic horsepower rating per belt, locate the rpm of the faster shaft in the left-hand column. Read on this line across to the column headed by the diameter of the smaller sheave. The figure given is the basic horsepower rating. For convenience the standard motor speeds are grouped at the beginning of the chart. On the same horizontal line read the "add-on" rating in the column headed by the drive speed ratio. Add the basic rating to the "add-on" rating to obtain the total horsepower rating per belt.

## Rated Horsepower per belt - For B Section Premium Belts

RPM of Faster Shaft	Basic Horsepower per Belt										
	Small Sheave Datum Diameter										
	4.60	5.00	5.20	5.40	5.60	6.00	6.40	6.80	7.40	8.60	9.40
725	4.50	5.50	6.00	6.50	6.99	7.98	8.96	9.93	11.4	14.3	16.1
870	5.20	6.38	6.97	7.56	8.14	9.31	10.5	11.6	13.3	16.7	18.9
950	5.57	6.85	7.49	8.13	8.76	10.0	11.3	12.5	14.4	18.0	20.4
1160	6.50	8.03	8.79	9.55	10.3	11.8	13.3	14.8	17.0	21.3	24.1
1425	7.58	9.41	10.3	11.2	12.1	13.9	15.7	17.5	20.1	25.1	28.4
1750	8.76	11.0	12.0	13.1	14.2	16.3	18.4	20.5	23.5	29.4	33.1
2850	11.7	14.8	16.4	17.9	19.4	22.4	25.2	28.0	31.9		
3450	12.5	16.0	17.7	19.4	21.1	24.2	27.3	30.1			
200	1.55	1.85	2.00	2.15	2.30	2.60	2.90	3.19	3.64	4.51	5.10
400	2.77	3.35	3.64	3.92	4.21	4.78	5.35	5.91	6.75	8.42	9.53
600	3.86	4.70	5.12	5.54	5.96	6.79	7.61	8.43	9.65	12.1	13.7
800	4.87	5.96	6.51	7.05	7.59	8.67	9.74	10.8	12.4	15.5	17.6
1000	5.80	7.14	7.81	8.47	9.13	10.5	11.8	13.1	15.0	18.8	21.3
1200	6.67	8.25	9.03	9.81	10.6	12.1	13.7	15.2	17.4	21.9	24.8
1400	7.48	9.29	10.2	11.1	12.0	13.7	15.5	17.2	19.8	24.8	28.0
1600	8.23	10.3	11.3	12.3	13.3	15.2	17.2	19.1	22.0	27.5	31.0
1800	8.93	11.2	12.3	13.4	14.5	16.6	18.8	20.9	24.0	30.0	33.8
2000	9.57	12.0	13.2	14.4	15.6	18.0	20.3	22.5	25.9	32.2	36.2
2200	10.2	12.8	14.1	15.4	16.7	19.2	21.6	24.1	27.6	34.3	38.4
2400	10.7	13.5	14.9	16.3	17.6	20.3	22.9	25.4	29.1	36.0	40.3
2600	11.2	14.1	15.6	17.1	18.5	21.3	24.0	26.7	30.5	37.6	
2800	11.6	14.7	16.2	17.8	19.3	22.2	25.0	27.8	31.7		
3000	11.9	15.2	16.8	18.4	19.9	23.0	25.9	28.7	32.6		
3200	12.2	15.6	17.3	18.9	20.5	23.6	26.6	29.4	33.4		
3400	12.4	15.9	17.6	19.3	21.0	24.1	27.1	30.0			
3600	12.6	16.2	17.9	19.6	21.3	24.5	27.5				
3800	12.6	16.3	18.1	19.8	21.5	24.8					
4000	12.6	16.4	18.2	19.9	21.6						



# HORSEPOWER RATINGS for BPR BELTS



An Altra Industrial Motion Company

The combined Arc-Length correction factor shown in the Classical pre-engineered drive tables or in the Arc-of-Contact correction factor table and the Belt Length correction factor table, page B2-15, should be applied to the total hp per belt before determining the number of belts required for the drive.

RPM of Faster Shaft	"Add-on" Horsepower rating per Belt									
	Speed Ratio									
	1.00	1.02	1.03	1.05	1.06	1.08	1.10	1.14	1.20	1.29
	1.01	1.02	1.04	1.05	1.07	1.10	1.13	1.19	1.28	over
725	0.00	0.05	0.11	0.16	0.22	0.27	0.33	0.38	0.43	0.49
870	0.00	0.07	0.13	0.20	0.26	0.33	0.39	0.46	0.52	0.59
950	0.00	0.07	0.14	0.21	0.28	0.36	0.43	0.50	0.57	0.64
1160	0.00	0.09	0.17	0.26	0.35	0.44	0.52	0.61	0.70	0.78
1425	0.00	0.11	0.21	0.32	0.43	0.53	0.64	0.75	0.85	0.96
1750	0.00	0.13	0.26	0.39	0.53	0.66	0.79	0.92	1.05	1.18
2850	0.00	0.21	0.43	0.64	0.86	1.07	1.28	1.50	1.71	1.92
3450	0.00	0.26	0.52	0.78	1.04	1.29	1.55	1.81	2.07	2.33
200	0.00	0.01	0.03	0.04	0.06	0.08	0.09	0.10	0.12	0.13
400	0.00	0.03	0.06	0.09	0.12	0.15	0.18	0.21	0.24	0.27
600	0.00	0.04	0.09	0.14	0.18	0.23	0.27	0.31	0.36	0.40
800	0.00	0.06	0.12	0.18	0.24	0.30	0.36	0.42	0.48	0.54
1000	0.00	0.07	0.15	0.22	0.30	0.38	0.45	0.52	0.60	0.67
1200	0.00	0.09	0.18	0.27	0.36	0.45	0.54	0.63	0.72	0.81
1400	0.00	0.10	0.21	0.31	0.42	0.52	0.63	0.73	0.84	0.94
1600	0.00	0.12	0.24	0.36	0.48	0.60	0.72	0.84	0.96	1.08
1800	0.00	0.13	0.27	0.40	0.54	0.67	0.81	0.94	1.08	1.21
2000	0.00	0.15	0.30	0.45	0.60	0.75	0.90	1.05	1.20	1.35
2200	0.00	0.16	0.33	0.50	0.66	0.83	0.99	1.15	1.32	1.48
2400	0.00	0.18	0.36	0.54	0.72	0.90	1.08	1.26	1.44	1.62
2600	0.00	0.19	0.39	0.58	0.78	0.97	1.17	1.36	1.56	1.75
2800	0.00	0.21	0.42	0.63	0.84	1.05	1.26	1.47	1.68	1.89
3000	0.00	0.22	0.45	0.67	0.90	1.13	1.35	1.57	1.80	2.02
3200	0.00	0.24	0.48	0.72	0.96	1.20	1.44	1.68	1.92	2.16
3400	0.00	0.25	0.51	0.76	1.02	1.28	1.53	1.78	2.04	2.29
3600	0.00	0.27	0.54	0.81	1.08	1.35	1.62	1.89	2.16	2.43
3800	0.00	0.28	0.57	0.85	1.14	1.42	1.71	1.99	2.28	2.56
4000	0.00	0.30	0.60	0.90	1.20	1.50	1.80	2.10	2.40	2.70

Classical horsepower ratings per belt are listed below and on the facing page. To obtain the basic horsepower rating per belt, locate the rpm of the faster shaft in the left-hand column. Read on this line across to the column headed by the diameter of the smaller sheave. The figure given is the basic horsepower rating. For convenience the standard motor speeds are grouped at the beginning of the chart. On the same horizontal line read the "add-on" rating in the column headed by the drive speed ratio. Add the basic rating to the "add-on" rating to obtain the total horsepower rating per belt.

### Rated Horsepower per belt - For C Section Premium Belts

RPM of Faster Shaft	Basic Horsepower per Belt												
	Small Sheave Datum Diameter												
	7.00	7.50	8.00	8.50	9.00	9.50	10.00	10.50	11.00	12.00	13.00	14.00	16.00
575	10.4	12.3	14.1	16.0	17.8	19.6	21.4	23.2	25.0	28.6	32.1	35.6	42.5
690	12.1	14.3	16.5	18.6	20.8	22.9	25.0	27.2	29.3	33.4	37.6	41.6	49.6
725	12.6	14.9	17.1	19.4	21.7	23.9	26.1	28.3	30.5	34.9	39.2	43.4	51.7
870	14.5	17.2	19.9	22.5	25.2	27.8	30.4	33.0	35.6	40.6	45.6	50.5	60.1
950	15.5	18.4	21.3	24.2	27.0	29.9	32.7	35.5	38.2	43.7	49.0	54.2	64.4
1160	18.0	21.5	24.9	28.3	31.7	35.0	38.3	41.5	44.8	51.1	57.3	63.3	74.8
1425	20.8	24.9	29.0	33.0	36.9	40.8	44.6	48.4	52.1	59.4	66.4	73.1	85.7
1750	23.7	28.5	33.2	37.9	42.4	46.9	51.2	55.5	59.6	67.6	75.2		
100	2.39	2.75	3.12	3.48	3.84	4.19	4.55	4.91	5.26	5.97	6.67	7.37	8.77
200	4.33	5.03	5.72	6.41	7.10	7.79	8.47	9.15	9.83	11.2	12.5	13.9	16.5
300	6.10	7.12	8.13	9.14	10.1	11.1	12.1	13.1	14.1	16.1	18.1	20.0	23.9
400	7.76	9.09	10.4	11.7	13.0	14.3	15.6	16.9	18.2	20.8	23.3	25.9	30.9
500	9.32	11.0	12.6	14.2	15.8	17.4	19.0	20.6	22.2	25.3	28.4	31.5	37.6
600	10.8	12.7	14.7	16.6	18.5	20.4	22.2	24.1	26.0	29.7	33.3	36.9	44.1
700	12.2	14.5	16.7	18.9	21.0	23.2	25.4	27.5	29.6	33.8	38.0	42.1	50.2
800	13.6	16.1	18.6	21.0	23.5	25.9	28.4	30.8	33.2	37.9	42.6	47.2	56.1
900	14.9	17.7	20.4	23.2	25.9	28.6	31.3	33.9	36.6	41.8	46.9	51.9	61.8
1000	16.1	19.2	22.2	25.2	28.2	31.1	34.1	37.0	39.8	45.5	51.1	56.5	67.1
1200	18.4	22.0	25.5	29.0	32.5	35.9	39.3	42.6	45.9	52.4	58.8	64.9	76.6
1400	20.5	24.6	28.6	32.5	36.4	40.3	44.1	47.8	51.5	58.7	65.6	72.3	84.7
1600	22.4	26.9	31.3	35.7	40.0	44.2	48.4	52.4	56.4	64.1	71.5	78.4	
1800	24.0	29.0	33.8	38.5	43.2	47.7	52.1	56.4	60.6	68.7	76.3		
2000	25.4	30.7	35.9	40.9	45.9	50.6	55.3	59.8	64.1	72.4			
2200	26.6	32.2	37.7	43.0	48.1	53.1	57.8	62.4					
2400	27.5	33.3	39.0	44.5	49.8	54.9							
2600	28.1	34.2	40.0	45.7	51.0								
2800	28.4	34.6	40.6										
3000	28.3	34.7											

# HORSEPOWER RATINGS for CPR BELTS



An Altra Industrial Motion Company

The combined Arc-Length correction factor shown in the Classical pre-engineered drive tables or in the Arc-of-Contact correction factor table and the Belt Length correction factor table, page B2-15, should be applied to the total hp per belt before determining the number of belts required for the drive.

RPM of Faster Shaft	"Add-on" Horsepower rating per Belt									
	Speed Ratio									
	1.00	1.02	1.03	1.05	1.06	1.08	1.10	1.14	1.20	1.29
	1.01	1.02	1.04	1.05	1.07	1.10	1.13	1.19	1.28	over
575	0.00	0.12	0.24	0.35	0.47	0.59	0.71	0.82	0.94	1.06
690	0.00	0.14	0.28	0.42	0.56	0.71	0.85	0.99	1.13	1.27
725	0.00	0.15	0.30	0.45	0.59	0.74	0.89	1.04	1.19	1.34
870	0.00	0.18	0.36	0.53	0.71	0.89	1.07	1.25	1.42	1.60
950	0.00	0.19	0.39	0.58	0.78	0.97	1.17	1.36	1.56	1.75
1160	0.00	0.24	0.47	0.71	0.95	1.19	1.42	1.66	1.90	2.14
1425	0.00	0.29	0.58	0.88	1.17	1.46	1.75	2.04	2.33	2.62
1750	0.00	0.36	0.72	1.07	1.43	1.79	2.15	2.51	2.87	3.22
100	0.00	0.02	0.04	0.06	0.08	0.10	0.12	0.14	0.16	0.18
200	0.00	0.04	0.08	0.12	0.16	0.20	0.25	0.29	0.33	0.37
300	0.00	0.06	0.12	0.18	0.25	0.31	0.37	0.43	0.49	0.55
400	0.00	0.08	0.16	0.25	0.33	0.41	0.49	0.57	0.65	0.74
500	0.00	0.10	0.20	0.31	0.41	0.51	0.61	0.72	0.82	0.92
600	0.00	0.12	0.25	0.37	0.49	0.61	0.74	0.86	0.98	1.11
700	0.00	0.14	0.29	0.43	0.57	0.72	0.86	1.00	1.15	1.29
800	0.00	0.16	0.33	0.49	0.66	0.82	0.98	1.15	1.31	1.47
900	0.00	0.18	0.37	0.55	0.74	0.92	1.11	1.29	1.47	1.66
1000	0.00	0.20	0.41	0.61	0.82	1.02	1.23	1.43	1.64	1.84
1200	0.00	0.25	0.49	0.74	0.98	1.23	1.47	1.72	1.96	2.21
1400	0.00	0.29	0.57	0.86	1.15	1.43	1.72	2.01	2.29	2.58
1600	0.00	0.33	0.65	0.98	1.31	1.64	1.96	2.29	2.62	2.95
1800	0.00	0.37	0.74	1.11	1.47	1.84	2.21	2.58	2.95	3.32
2000	0.00	0.41	0.82	1.23	1.64	2.05	2.46	2.87	3.27	3.68
2200	0.00	0.45	0.90	1.35	1.80	2.25	2.70	3.15	3.60	4.05
2400	0.00	0.49	0.98	1.47	1.97	2.46	2.95	3.44	3.93	4.42
2600	0.00	0.53	1.06	1.60	2.13	2.66	3.19	3.73	4.26	4.79
2800	0.00	0.57	1.15	1.72	2.29	2.87	3.44	4.01	4.58	5.16
3000	0.00	0.61	1.23	1.84	2.46	3.07	3.68	4.30	4.91	5.53



# Wood's Sure-Grip™ QD Bushings

**A1**



- **Provide a True Clamp Fit**
- **Are Easy to Install and Remove**
- **Permit Four-Way Mounting**

Sure-Grip® “Quick Detachable” bushings are easy to install and remove. They are split through flange and taper to provide a true clamp on the shaft that is the equivalent of a shrink fit. All sizes except JA and QT have a setscrew over the key to help

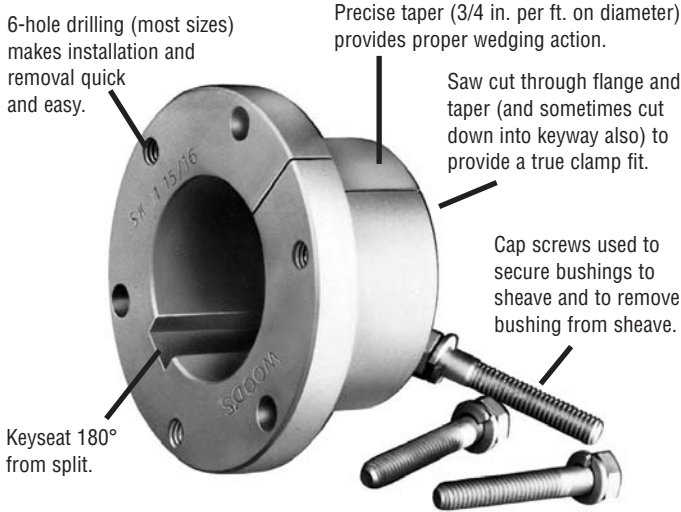

maintain the bushing's position on the shaft until the cap screws are securely tightened. Sure-Grip bushings have a very gradual taper (3/4-inch taper per ft. on the diameter) which is about half the inclined angle of many other bushings. The result is the Sure-Grip securely clamps the shaft, with twice the force of those competitive bushings, to provide extreme holding power.

Versatile Sure-Grip bushings permit the mounting of the same mating part on shafts of different diameters, and the mounting of different sheaves on the same shaft using the same bushing. Their interchangeability extends through sheaves, pulleys, timing pulleys, sprockets, flexible and rigid couplings, made-to-order items by Wood's, and to product lines of several other mechanical power transmission manufacturers.

Sure-Grip bushings are manufactured with the drilled and tapped holes located at a precise distance from the keyseat; thus, a wide mating part having a bushing in each end can be mounted on a common shaft with the two keyways in line. This feature not only facilitates installation but also permits both bushings to carry an equal share of the load.

**STANDARD MOUNTING**

**REVERSE MOUNTING**

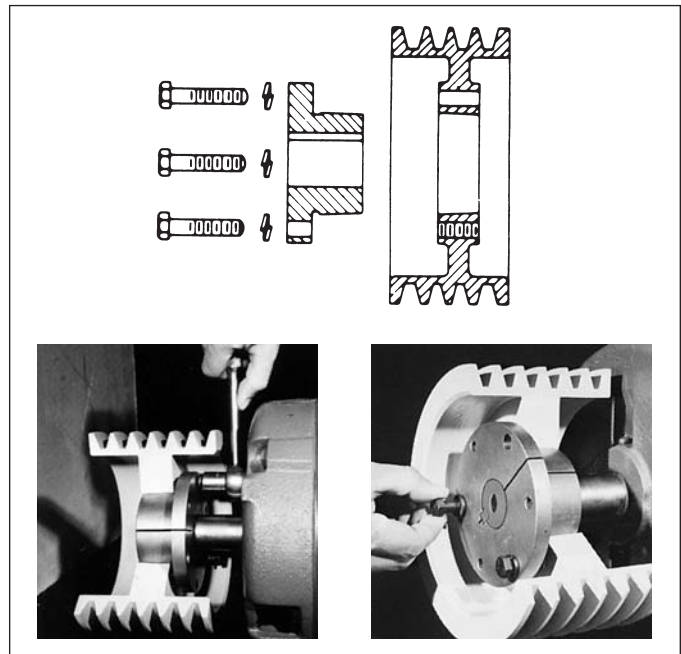
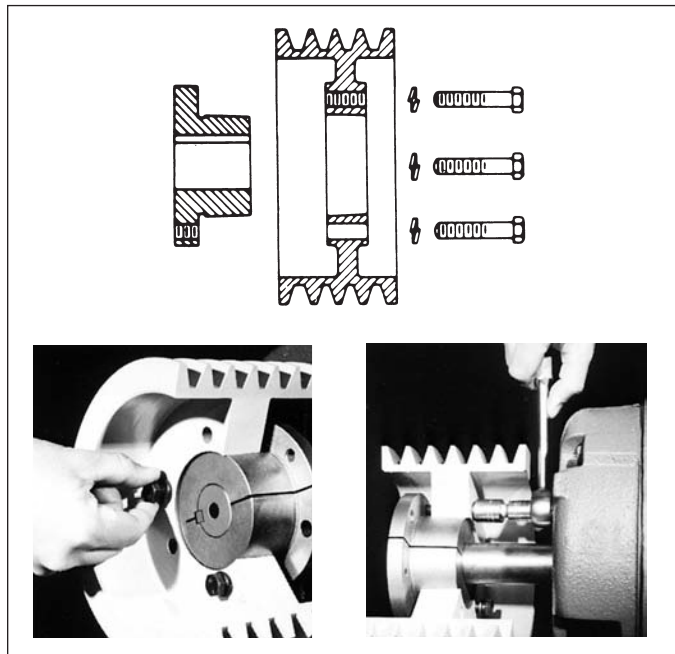

1. Cap screws from outside through drilled holes in the mating part and into threaded holes in the bushing flange located on the inside of the assembly. Or the complete assembly reversed on the shaft and;
2. Cap screws from inside through drilled holes in the mating part and into threaded holes in the bushing flange located on the outside of the assembly.

3. Cap screws from inside through drilled holes in the bushing flange located on the inside of the assembly and into threaded holes in the mating part.
4. Cap screws from outside through drilled holes in the bushing flange located on the outside of the assembly and into threaded holes in the mating part.

# SURE-GRIP BUSHING DIMENSIONS

Sure-Grip bushings are designed to transmit the rated torque capacity listed in the table below when the cap screws are tightened as indicated. The bushings are stocked in all popular bore sizes, including metric bores, within the bore range for a particular bushing.

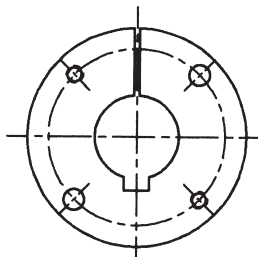

Bushing  
QT

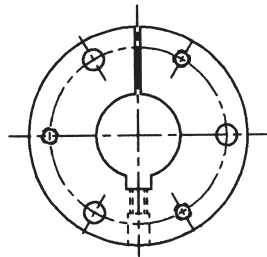

Bushings  
JA to J inclusive  
w/Setscrew  
Except JA

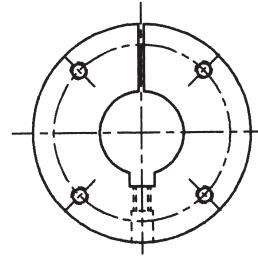

Bushings  
M to S inclusive  
w/Setscrew

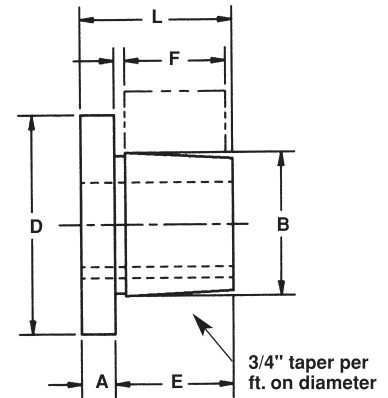

## SURE-GRIP BUSHING TORQUE RATINGS AND DIMENSIONS

Bush.	Torque Capacity (In.-Lbs.)	(Note 1) Max. Bore	(Note 2) Max. Bore	DIMENSIONS IN INCHES						Bolt Circle	Cap Screws Required
				A	B	D	E	F*	L		
QT	1,750	1½	30	¼	1.625	2½	1	7/8	1¼	2	2-¼ x 1
JA	1,750	1¼	23	5/16	1.375	2	11/16	9/16	1	1 21/32	3 - #10 x 1
SH	3,500	1 5/8	36	3/8	1.871	2 11/16	7/8	13/16	1¼	2¼	3-¼ x 1 3/8
SDS	5,000	1 15/16	42	7/16	2.1875	3 3/16	7/8	3/4	1 5/16	2 11/16	3-¼ x 1 3/8
SD	5,000	1 15/16	42	7/16	2.1875	3 3/16	1 3/8	1¼	1 13/16	2 11/16	3-¼ x 1 7/8
SK	7,000	2½	56	½	2.8125	3 7/8	1 3/8	1¼	1 7/8	3 5/16	3-5/16 x 2
SF	11,000	2 15/16	63	½	3.125	4 5/8	1½	1¼	2	3 7/8	3-3/8 x 2
E	20,000	3½	78	¾	3.834	6	1 7/8	1 5/8	2 5/8	5	3-½ x 2 3/4
F	40,000	3 15/16	90	13/16	4.4375	6 5/8	2 13/16	2½	3 5/8	5 5/8	3-9/16 x 3 5/8
J	55,000	4½	105	1	5.1484	7¼	3½	3 3/16	4½	6¼	3-5/8 x 4½
M	125,000	5½	130	1¼	6.500	9 1/8	5½	5 3/16	6 3/4	7 7/8	4-3/4 x 6 3/4
N	150,000	6	140	1½	7.000	10	6 5/8	6¼	8 1/8	8½	4-7/8 x 8
P	250,000	7	160	1 3/4	8.250	11 3/4	7 5/8	7¼	9 3/8	10	4 - 1 x 9 1/2
W	375,000	8½	200	2	10.437	15	9 3/8	9	11 3/8	12 3/4	4 - 1 1/8 x 11 1/2
S	625,000	10	240	3¼	12.125	17 3/4	12½	12	15 3/4	15	5 - 1¼ x 15 1/2

\* Mating hub length.

1. MAX INCH BORE WITH KEYSEAT.
2. MAX MM BORE WITH STANDARD KEYSEAT.

See pages A1-4 to A1-8 for Bore and Keyseat information and weights.

(Inches)

Sure-Grip Bushings are available from stock with all the bores and keyseats listed below. In some cases, as the bore increases in diameter, a shallow keyseat is provided—due to insufficient metal thickness. When this happens, Wood's furnishes the correct rectangular key to suit at no charge. This does not affect the bushing's ability to transmit the load. The rectangular key, or flat key as some call it, fits into the standard keyway in the shaft.

Product No.	Bore	Key Seat	Wt. (*)
<b>QT BUSHINGS</b>			
QTMPB	7/16	No KS	.6
QT12	1/2	1/8 x 1/16	.6
QT9/16	9/16	1/8 x 1/16	.6
QT58	5/8	3/16 x 3/32	.6
QT11/16	11/16	3/16 x 3/32	.6
QT34	3/4	3/16 x 3/32	.6
QT13/16	13/16	3/16 x 3/32	.6
QT78	7/8	3/16 x 3/32	.6
QT15/16	15/16	1/4 x 1/8	.6
QT1	1	1/4 x 1/8	.6
QT1116	1-1/16	1/4 x 1/8	.6
QT118	1-1/8	1/4 x 1/8	.6
QT1316	1-3/16	1/4 x 1/8	.6
QT114	1-1/4	1/4 x 1/8	.6
QT1516	1-5/16	5/16 x 1/16	.6
QT138	1-3/8	5/16 x 1/16	.6
QT1716	1-7/16	3/8 x 1/16	.6
QT112	1-1/2	3/8 x 1/16	.6
<b>JA BUSHINGS</b>			
JAMPB	1/2	No KS	.8
JA12	1/2	1/8 x 1/16	.8
JA9/16	9/16	1/8 x 1/16	.8
JA58	5/8	3/16 x 3/32	.8
JA11/16	11/16	3/16 x 3/32	.8
JA34	3/4	3/16 x 3/32	.8
JA13/16	13/16	3/16 x 3/32	.8
JA78	7/8	3/16 x 3/32	.8
JA15/16	15/16	1/4 x 1/8	.8
JA1	1	1/4 x 1/8	.8
JA1116	1-1/16	1/4 x 1/16	.8
JA118	1-1/8	1/4 x 1/16	.8
JA1316	1-3/16	1/4 x 1/16	.8
JA114	1-1/4	1/4 x 1/32	.8
<b>SH BUSHINGS</b>			
SHMPB	7/16	No KS	1.1
SH12	1/2	1/8 x 1/16	1.1
SH9/16	9/16	1/8 x 1/16	1.1
SH58	5/8	3/16 x 3/32	1.1
SH11/16	11/16	3/16 x 3/32	1.0
SH34	3/4	3/16 x 3/32	1.0
SH13/16	13/16	3/16 x 3/32	1.0
SH78	7/8	3/16 x 3/32	1.0
SH15/16	15/16	1/4 x 1/8	1.0
SH1	1	1/4 x 1/8	.9

Product No.	Bore	Key Seat	Wt. (*)
<b>SH BUSHINGS (continued)</b>			
SH1116	1-1/16	1/4 x 1/8	.9
SH118	1-1/8	1/4 x 1/8	.9
SH1316	1-3/16	1/4 x 1/8	.8
SH114	1-1/4	1/4 x 1/8	.8
SH1516	1-5/16	5/16 x 5/32	.7
SH138	1-3/8	5/16 x 5/32	.7
SH1716	1-7/16	3/8 x 1/16	.7
SH112	1-1/2	3/8 x 1/16	.6
SH1916	1-9/16	3/8 x 1/16	.6
SH158	1-5/8	3/8 x 1/16	.5
SH11116	1-11/16	No KS	.5
<b>SDS BUSHINGS</b>			
SDSMPB	7/16	No KS	1.7
SDS12	1/2	1/8 x 1/16	1.7
SDS9/16	9/16	1/8 x 1/16	1.7
SDS58	5/8	3/16 x 3/32	1.6
SDS11/16	11/16	3/16 x 3/32	1.6
SDS34	3/4	3/16 x 3/32	1.6
SDS13/16	13/16	3/16 x 3/32	1.6
SDS78	7/8	3/16 x 3/32	1.5
SDS15/16	15/16	1/4 x 1/8	1.5
SDS1	1	1/4 x 1/8	1.5
SDS1116	1-1/16	1/4 x 1/8	1.4
SDS118	1-1/8	1/4 x 1/8	1.4
SDS1316	1-3/16	1/4 x 1/8	1.4
SDS114	1-1/4	1/4 x 1/8	1.3
SDS1516	1-5/16	5/16 x 5/32	1.3
SDS138	1-3/8	5/16 x 5/32	1.2
SDS13838KS	1-3/8	3/8 x 3/16	1.2
SDS1716	1-7/16	3/8 x 3/16	1.2
SDS112	1-1/2	3/8 x 3/16	1.1
SDS1916	1-9/16	3/8 x 3/16	1.1
SDS158	1-5/8	3/8 x 3/16	1.0
SDS11116	1-11/16	3/8 x 3/16	1.0
SDS134	1-3/4	3/8 x 1/8	1.0
SDS11316	1-13/16	1/2 x 1/8	.9
SDS178	1-7/8	1/2 x 1/16	.9
SDS11516	1-15/16	1/2 x 1/16	.8
SDS2	2	No KS	.7
<b>SD BUSHINGS</b>			
SDMPB	7/16	No KS	2.1
SD12	1/2	1/8 x 1/16	2.1
SD9/16	9/16	1/8 x 1/16	2.1
SD58	5/8	3/16 x 3/32	2.1
SD11/16	11/16	3/16 x 3/32	2.0

Product No.	Bore	Key Seat	Wt. (*)
<b>SD BUSHINGS (continued)</b>			
SD34	3/4	3/16 x 3/32	2.0
SD13/16	13/16	3/16 x 3/32	2.0
SD78	7/8	3/16 x 3/32	1.9
SD15/16	15/16	1/4 x 1/8	1.9
SD1	1	1/4 x 1/8	1.8
SD1116	1-1/16	1/4 x 1/8	1.8
SD118	1-1/8	1/4 x 1/8	1.7
SD1316	1-3/16	1/4 x 1/8	1.7
SD114	1-1/4	1/4 x 1/8	1.6
SD1516	1-5/16	5/16 x 5/32	1.6
SD138	1-3/8	5/16 x 5/32	1.5
SD13838KS	1-3/8	3/8 x 3/16	1.5
SD1716	1-7/16	3/8 x 3/16	1.4
SD112	1-1/2	3/8 x 3/16	1.4
SD1916	1-9/16	3/8 x 3/16	1.3
SD158	1-5/8	3/8 x 3/16	1.2
SD11116	1-11/16	3/8 x 3/16	1.2
SD134	1-3/4	3/8 x 1/8	1.1
SD11316	1-13/16	1/2 x 1/8	1.1
SD178	1-7/8	1/2 x 1/16	1.0
SD11516	1-15/16	1/2 x 1/16	.9
SD2	2	No KS	.8
<b>SK BUSHINGS</b>			
SKMPB	7/16	No KS	3.6
SK12	1/2	1/8 x 1/16	3.6
SK9/16	9/16	1/8 x 1/16	3.6
SK58	5/8	3/16 x 3/32	3.6
SK11/16	11/16	3/16 x 3/32	3.5
SK34	3/4	3/16 x 3/32	3.5
SK13/16	13/16	3/16 x 3/32	3.5
SK78	7/8	3/16 x 3/32	3.4
SK15/16	15/16	1/4 x 1/8	3.4
SK1	1	1/4 x 1/8	3.3
SK1116	1-1/16	1/4 x 1/8	3.3
SK118	1-1/8	1/4 x 1/8	3.2
SK1316	1-3/16	1/4 x 1/8	3.2
SK114	1-1/4	1/4 x 1/8	3.1
SK1516	1-5/16	5/16 x 5/32	3.1
SK151638KS	1-5/16	3/8 x 3/16	3.1
SK138	1-3/8	5/16 x 5/32	3.0
SK13838KS	1-3/8	3/8 x 3/16	3.0
SK1716	1-7/16	3/8 x 3/16	2.9
SK112	1-1/2	3/8 x 3/16	2.9
SK1916	1-9/16	3/8 x 3/16	2.8
SK158	1-5/8	3/8 x 3/16	2.7
SK11116	1-11/16	3/8 x 3/16	2.6
SK134	1-3/4	3/8 x 3/16	2.5
SK13412KS	1-3/4	1/2 x 1/4	2.5

\* Approximate weight in lbs.

MPB Bushings are unsplit.

(Continued—next page)



# SURE-GRIP BUSHINGS BORE AND KEYSEAT DIMENSIONS

(Inches)

Product No.	Bore	Key Seat	Wt. (*)
<b>SK BUSHINGS (continued)</b>			
SK11316	1-13/16	1/2 x 1/4	2.4
SK178	1-7/8	1/2 x 1/4	2.4
SK11516	1-15/16	1/2 x 1/4	2.3
SK2	2	1/2 x 1/4	2.2
SK2116	2-1/16	1/2 x 1/4	2.1
SK218	2-1/8	1/2 x 1/4	2.0
SK2316	2-3/16	1/2 x 1/8	2.0
SK214	2-1/4	1/2 x 1/8	1.9
SK21458KS	2-1/4	5/8 x 1/8	1.9
SK2516	2-5/16	5/8 x 1/16	1.8
SK238	2-3/8	5/8 x 1/16	1.7
SK2716	2-7/16	5/8 x 1/16	1.6
SK212	2-1/2	5/8 x 1/16	1.5
SK2916	2-9/16	No KS	1.3
SK258	2-5/8	No KS	1.1
<b>SF BUSHINGS</b>			
SFMPB	1/2	No KS	5.1
SF12	1/2	1/8 x 1/16	5.1
SF58	5/8	3/16 x 3/32	5.0
SF34	3/4	3/16 x 3/32	5.0
SF78	7/8	3/16 x 3/32	4.9
SF15/16	15/16	1/4 x 1/8	4.8
SF1	1	1/4 x 1/8	4.8
SF1116	1-1/16	1/4 x 1/8	4.7
SF118	1-1/8	1/4 x 1/8	4.7
SF1316	1-3/16	1/4 x 1/8	4.6
SF114	1-1/4	1/4 x 1/8	4.5
SF1516	1-5/16	5/16 x 5/32	4.5
SF138	1-3/8	5/16 x 5/32	4.4
SF13838KS	1-3/8	3/8 x 3/16	4.4
SF1716	1-7/16	3/8 x 3/16	4.3
SF112	1-1/2	3/8 x 3/16	4.2
SF1916	1-9/16	3/8 x 3/16	4.2
SF158	1-5/8	3/8 x 3/16	4.1
SF11116	1-11/16	3/8 x 3/16	4.0
SF134	1-3/4	3/8 x 3/16	3.9
SF11316	1-13/16	1/2 x 1/4	3.8
SF178	1-7/8	1/2 x 1/4	3.7
SF11516	1-15/16	1/2 x 1/4	3.6
SF2	2	1/2 x 1/4	3.5
SF2116	2-1/16	1/2 x 1/4	3.4
SF218	2-1/8	1/2 x 1/4	3.3
SF2316	2-3/16	1/2 x 1/4	3.2
SF214	2-1/4	1/2 x 1/4	3.1
SF21458KS	2-1/4	5/8 x 5/16	3.1
SF2516	2-5/16	5/8 x 3/16	3.1
SF238	2-3/8	5/8 x 3/16	3.0
SF2716	2-7/16	5/8 x 3/16	2.9
SF212	2-1/2	5/8 x 3/16	2.8
SF2916	2-9/16	5/8 x 1/16	2.6
SF258	2-5/8	5/8 x 1/16	2.5
SF21116	2-11/16	5/8 x 1/16	2.4
SF234	2-3/4	5/8 x 1/16	2.2
SF278	2-7/8	3/4 x 1/16	1.8
SF21516	2-15/16	3/4 x 1/32	1.7

Product No.	Bore	Key Seat	Wt. (*)
<b>E BUSHINGS</b>			
EMPB	7/8	No KS	10.8
E78	7/8	3/16 x 3/32	10.8
E15/16	15/16	1/4 x 1/8	10.8
E1	1	1/4 x 1/8	10.7
E118	1-1/8	1/4 x 1/8	10.6
E1316	1-3/16	1/4 x 1/8	10.5
E114	1-1/4	1/4 x 1/8	10.4
E1516	1-5/16	5/16 x 5/32	10.3
E138	1-3/8	5/16 x 5/32	10.2
E13838KS	1-3/8	3/8 x 3/16	10.2
E1716	1-7/16	3/8 x 3/16	10.1
E112	1-1/2	3/8 x 3/16	10.0
E1916	1-9/16	3/8 x 3/16	9.9
E158	1-5/8	3/8 x 3/16	9.8
E11116	1-11/16	3/8 x 3/16	9.7
E134	1-3/4	3/8 x 3/16	9.6
E11316	1-13/16	1/2 x 1/4	9.4
E178	1-7/8	1/2 x 1/4	9.3
E11516	1-15/16	1/2 x 1/4	9.2
E2	2	1/2 x 1/4	9.0
E2116	2-1/16	1/2 x 1/4	8.9
E218	2-1/8	1/2 x 1/4	8.8
E2316	2-3/16	1/2 x 1/4	8.6
E214	2-1/4	1/2 x 1/4	8.5
E21458KS	2-1/4	5/8 x 5/16	8.5
E2516	2-5/16	5/8 x 5/16	8.3
E238	2-3/8	5/8 x 5/16	8.1
E2716	2-7/16	5/8 x 5/16	8.0
E212	2-1/2	5/8 x 5/16	7.8
E2916	2-9/16	5/8 x 5/16	7.6
E258	2-5/8	5/8 x 5/16	7.5
E2116	2-11/16	5/8 x 5/16	7.3
E234	2-3/4	5/8 x 5/16	7.1
E21316	2-13/16	3/4 x 3/8	7.2
E278	2-7/8	3/4 x 3/8	7.1
E21516	2-15/16	3/4 x 1/8	6.9
E3	3	3/4 x 1/8	6.7
E318	3-1/8	3/4 x 1/8	6.3
E3316	3-3/16	3/4 x 1/8	6.0
E314	3-1/4	3/4 x 1/8	5.8
E3516	3-5/16	7/8 x 1/16	5.7
E338	3-3/8	7/8 x 1/16	5.5
E3716	3-7/16	7/8 x 1/16	5.2
E312	3-1/2	7/8 x 1/16	4.7
<b>F BUSHINGS</b>			
FMPB	1	No KS	17.9
F1	1	1/4 x 1/8	17.9
F118	1-1/8	1/4 x 1/8	17.7
F1316	1-3/16	1/4 x 1/8	17.6
F114	1-1/4	1/4 x 1/8	17.5
F138	1-3/8	5/16 x 5/32	17.2
F1716	1-7/16	3/8 x 3/16	17.1
F112	1-1/2	3/8 x 3/16	16.9
F1916	1-9/16	3/8 x 3/16	16.8
F158	1-5/8	3/8 x 3/16	16.7

Product No.	Bore	Key Seat	Wt. (*)
<b>F BUSHINGS (continued)</b>			
F134	1-3/4	3/8 x 3/16	16.3
F178	1-7/8	1/2 x 1/4	16.0
F11516	1-15/16	1/2 x 1/4	15.8
F2	2	1/2 x 1/4	15.6
F2116	2-1/16	1/2 x 1/4	15.4
F218	2-1/8	1/2 x 1/4	15.2
F2316	2-3/16	1/2 x 1/4	15.0
F214	2-1/4	1/2 x 1/4	14.8
F21458KS	2-1/4	5/8 x 5/16	14.8
F2516	2-5/16	5/8 x 5/16	14.5
F238	2-3/8	5/8 x 5/16	14.3
F2716	2-7/16	5/8 x 5/16	14.1
F212	2-1/2	5/8 x 5/16	13.9
F2916	2-9/16	5/8 x 5/16	13.7
F258	2-5/8	5/8 x 5/16	13.4
F21116	2-11/16	5/8 x 5/16	13.2
F234	2-3/4	5/8 x 5/16	12.9
F21316	2-13/16	3/4 x 3/8	12.6
F278	2-7/8	3/4 x 3/8	12.3
F21516	2-15/16	3/4 x 3/8	12.1
F3	3	3/4 x 3/8	11.8
F318	3-1/8	3/4 x 3/8	11.2
F3316	3-3/16	3/4 x 3/8	10.9
F314	3-1/4	3/4 x 3/8	10.6
F3516	3-5/16	7/8 x 3/16	11.0
F338	3-3/8	7/8 x 3/16	10.6
F3716	3-7/16	7/8 x 3/16	10.3
F312	3-1/2	7/8 x 3/16	10.0
F358	3-5/8	7/8 x 3/16	9.4
F31116	3-11/16	7/8 x 3/16	9.0
F334	3-3/4	7/8 x 3/16	8.7
F378	3-7/8	1 x 1/8	8.1
F31516	3-15/16	1 x 1/8	7.7
F4	4	No KS	6.9
<b>J BUSHINGS</b>			
JMPB	1-7/16	No KS	28.1
J1716	1-7/16	3/8 x 3/16	28.1
J112	1-1/2	3/8 x 3/16	28.0
J1916	1-9/16	3/8 x 3/16	27.8
J11116	1-11/16	3/8 x 3/16	27.4
J134	1-3/4	3/8 x 3/16	27.2
J178	1-7/8	1/2 x 1/4	26.7
J11516	1-15/16	1/2 x 1/4	26.5
J2	2	1/2 x 1/4	26.3
J218	2-1/8	1/2 x 1/4	25.8
J2316	2-3/16	1/2 x 1/4	25.6
J214	2-1/4	1/2 x 1/4	25.3
J2516	2-5/16	5/8 x 5/16	25.0
J238	2-3/8	5/8 x 5/16	24.7
J2716	2-7/16	5/8 x 5/16	24.5
J212	2-1/2	5/8 x 5/16	24.2
J258	2-5/8	5/8 x 5/16	23.6
J21116	2-11/16	5/8 x 5/16	23.3
J234	2-3/4	5/8 x 5/16	23.0
J278	2-7/8	3/4 x 3/8	22.2

\* Approximate weight in lbs.

MPB Bushings are unsplit.

(Continued—next page)

# SURE-GRIP BUSHINGS BORE AND KEYSEAT DIMENSIONS

(Inches)

Product No.	Bore	Key Seat	Wt. (*)
<b>J BUSHINGS (continued)</b>			
J21516	2-15/16	3/4 x 3/8	21.9
J3	3	3/4 x 3/8	21.6
J318	3-1/8	3/4 x 3/8	20.9
J3316	3-3/16	3/4 x 3/8	20.5
J314	3-1/4	3/4 x 3/8	20.1
J3516	3-5/16	7/8 x 7/16	19.6
J338	3-3/8	7/8 x 7/16	19.3
J3716	3-7/16	7/8 x 7/16	18.9
J312	3-1/2	7/8 x 7/16	18.5
J358	3-5/8	7/8 x 7/16	17.7
J31116	3-11/16	7/8 x 7/16	17.2
J334	3-3/4	7/8 x 7/16	16.8
J31316	3-13/16	1 x 1/2	17.4
J378	3-7/8	1 x 3/8	17.0
J31516	3-15/16	1 x 3/8	16.5
J4	4	1 x 1/8	16.1
J418	4-1/8	1 x 1/8	15.2
J4316	4-3/16	1 x 1/8	14.7
J414	4-1/4	1 x 1/8	14.2
J438	4-3/8	1 x 1/8	13.2
J4716	4-7/16	1 x 1/8	12.7
J412	4-1/2	1 x 1/8	12.2
<b>M BUSHINGS</b>			
M11516	1-15/16	1/2 x 1/4	63.7
M2	2	1/2 x 1/4	63.3
M2316	2-3/16	1/2 x 1/4	62.3
M214	2-1/4	1/2 x 1/4	61.9
M238	2-3/8	5/8 x 5/16	61.0
M2716	2-7/16	5/8 x 5/16	60.6
M212	2-1/2	5/8 x 5/16	60.1
M258	2-5/8	5/8 x 5/16	59.3
M21116	2-11/16	5/8 x 5/16	58.8
M234	2-3/4	5/8 x 5/16	58.3
M278	2-7/8	3/4 x 3/8	57.2
M21516	2-15/16	3/4 x 3/8	56.7
M3	3	3/4 x 3/8	56.2
M318	3-1/8	3/4 x 3/8	55.2
M3316	3-3/16	3/4 x 3/8	54.6
M314	3-1/4	3/4 x 3/8	54.1
M338	3-3/8	7/8 x 7/16	52.8
M3716	3-7/16	7/8 x 7/16	52.2
M312	3-1/2	7/8 x 7/16	51.6
M358	3-5/8	7/8 x 7/16	50.4
M31116	3-11/16	7/8 x 7/16	49.7
M334	3-3/4	7/8 x 7/16	49.1
M378	3-7/8	1 x 1/2	47.6
M31516	3-15/16	1 x 1/2	46.9
M4	4	1 x 1/2	46.2
M418	4-1/8	1 x 1/2	44.8
M4316	4-3/16	1 x 1/2	44.1
M414	4-1/4	1 x 1/2	43.4
M438	4-3/8	1 x 1/2	41.9
M4716	4-7/16	1 x 1/2	41.2

Product No.	Bore	Key Seat	Wt. (*)
<b>M BUSHINGS (continued)</b>			
M412	4-1/2	1 x 1/2	40.4
M41116	4-11/16	1-1/4 x 5/8	37.5
M434	4-3/4	1-1/4 x 5/8	36.7
M478	4-7/8	1-1/4 x 1/4	37.8
M41516	4-15/16	1-1/4 x 1/4	37.0
M5	5	1-1/4 x 1/4	36.1
M5316	5-3/16	1-1/4 x 1/4	33.5
M514	5-1/4	1-1/4 x 1/4	32.6
M5716	5-7/16	1-1/4 x 1/4	29.9
M512	5-1/2	1-1/4 x 1/4	28.9
<b>N BUSHINGS</b>			
N21516	2-15/16	3/4 x 3/8	84.1
N3	3	3/4 x 3/8	83.5
N338	3-3/8	7/8 x 7/16	79.3
N3716	3-7/16	7/8 x 7/16	78.6
N312	3-1/2	7/8 x 7/16	77.9
N358	3-5/8	7/8 x 7/16	76.4
N334	3-3/4	7/8 x 7/16	74.9
N378	3-7/8	1 x 1/2	73.1
N31516	3-15/16	1 x 1/2	72.3
N4	4	1 x 1/2	71.5
N4316	4-3/16	1 x 1/2	68.9
N414	4-1/4	1 x 1/2	68.1
N438	4-3/8	1 x 1/2	66.3
N4716	4-7/16	1 x 1/2	65.4
N412	4-1/2	1 x 1/2	64.5
N458	4-5/8	1-1/4 x 5/8	62.0
N434	4-3/4	1-1/4 x 5/8	60.0
N478	4-7/8	1-1/4 x 5/8	58.1
N41516	4-15/16	1-1/4 x 5/8	57.0
N5	5	1-1/4 x 5/8	56.0
N5316	5-3/16	1-1/4 x 1/4	56.1
N5716	5-7/16	1-1/4 x 1/4	51.7
N512	5-1/2	1-1/4 x 1/4	50.6
N578	5-7/8	1-1/2 x 1/4	44.3
N51516	5-15/16	1-1/2 x 1/8	43.9
<b>P BUSHINGS</b>			
P21516	2-15/16	3/4 x 3/8	141.2
P314	3-1/4	3/4 x 3/8	137.6
P3716	3-7/16	7/8 x 7/16	134.9
P312	3-1/2	7/8 x 7/16	134.1
P358	3-5/8	7/8 x 7/16	132.4
P334	3-3/4	7/8 x 7/16	130.6
P378	3-7/8	1 x 1/2	128.5
P31516	3-15/16	1 x 1/2	127.6
P4	4	1 x 1/2	126.7
P414	4-1/4	1 x 1/2	122.7
P438	4-3/8	1 x 1/2	120.7
P4716	4-7/16	1 x 1/2	119.6
P412	4-1/2	1 x 1/2	118.6
P458	4-5/8	1-1/4 x 5/8	115.7
P41116	4-11/16	1-1/4 x 5/8	114.6

Product No.	Bore	Key Seat	Wt. (*)
<b>P BUSHINGS (continued)</b>			
P434	4-3/4	1-1/4 x 5/8	113.5
P478	4-7/8	1-1/4 x 5/8	111.2
P41516	4-15/16	1-1/4 x 5/8	110.0
P5	5	1-1/4 x 5/8	108.8
P5316	5-3/16	1-1/4 x 5/8	105.2
P514	5-1/4	1-1/4 x 5/8	103.9
P5516	5-5/16	1-1/4 x 5/8	102.7
P538	5-3/8	1-1/4 x 5/8	101.4
P5716	5-7/16	1-1/4 x 5/8	100.1
P512	5-1/2	1-1/4 x 5/8	98.8
P534	5-3/4	1-1/2 x 3/4	98.1
P578	5-7/8	1-1/2 x 3/4	95.3
P51516	5-15/16	1-1/2 x 3/4	93.9
P6	6	1-1/2 x 1/4	92.5
P6116	6-1/16	1-1/2 x 1/4	91.0
P614	6-1/4	1-1/2 x 1/4	86.6
P6716	6-7/16	1-1/2 x 1/4	83.5
P612	6-1/2	1-1/2 x 1/4	80.5
P634	6-3/4	1-3/4 x 1/8	74.7
P7	7	1-3/4 x 1/8	68.1
<b>W BUSHINGS</b>			
W414MPB	4-1/4	...	247.0
W478MPB	4-7/8	...	234.0
W514MPB	5-1/4	...	225.0
W578MPB	5-7/8	...	209.0
W612MPB	6-1/2	...	191.0
W714MPB	7-1/4	...	167.0
<b>S BUSHINGS</b>			
S6MPB	6	...	445.0
S8MPB	8	...	356.0
S9MPB	9	...	301.0

MPB bushings are unsplit.

\* Approximate weight in lbs.

# SURE-GRIP BUSHINGS (INCHES) WITH METRIC BORE AND KEYSEAT

## BORE AND KEY INFORMATION

Product No.	Bore (mm)	Key ■	Wt. (*)
<b>QT BUSHINGS</b>			
QT14MM	14	5 x 5	.6
QT15MM	15	5 x 5	.6
QT16MM	16	5 x 5	.6
QT18MM	18	6 x 6	.6
QT19MM	19	6 x 6	.6
QT20MM	20	6 x 6	.6
QT22MM	22	6 x 6	.6
QT24MM	24	8 x 7	.6
QT25MM	25	8 x 7	.6
QT28MM	28	8 x 7	.6
QT30MM	30	8 x 7	.6
QT32MM	32	10 x 6†	.6
QT35MM	35	10 x 6†	.6
QT38MM	38	10 x 6†	.6
<b>JA BUSHINGS</b>			
JA15MM	15	5 x 5	.8
JA16MM	16	5 x 5	.8
JA19MM	19	6 x 6	.8
JA20MM	20	6 x 6	.8
JA24MM	24	8 x 6†	.8
JA25MM	25	8 x 6†	.8
JA28MM	28	8 x 5†	.8
<b>SH BUSHINGS</b>			
SH24MM	24	8 x 7	.9
SH25MM	25	8 x 7	.9
SH28MM	28	8 x 7	.9
SH30MM	30	8 x 7	.8
SH32MM	32	10 x 8	.8
SH35MM	35	10 x 8	.7
<b>SDS BUSHINGS</b>			
SDS24MM	24	8 x 7	1.5
SDS25MM	25	8 x 7	1.5
SDS28MM	28	8 x 7	1.4
SDS30MM	30	8 x 7	1.4
SDS32MM	32	10 x 8	1.3
SDS35MM	35	10 x 8	1.2
SDS38MM	38	10 x 8	1.1
SDS40MM	40	12 x 8	1.1
SDS42MM	42	12 x 8	1.0
<b>SD BUSHINGS</b>			
SD24MM	24	8 x 7	1.8
SD25MM	25	8 x 7	1.8
SD28MM	28	8 x 7	1.7
SD30MM	30	8 x 7	1.7
SD32MM	32	10 x 8	1.6
SD35MM	35	10 x 8	1.5
SD38MM	38	10 x 8	1.4
SD40MM	40	12 x 8	1.3
SD42MM	42	12 x 8	1.2

Product No.	Bore (mm)	Key ■	Wt. (*)
<b>SK BUSHINGS</b>			
SK24MM	24	8 x 7	3.3
SK25MM	25	8 x 7	3.3
SK28MM	28	8 x 7	3.2
SK30MM	30	8 x 7	3.2
SK32MM	32	10 x 8	3.1
SK35MM	35	10 x 8	3.0
SK38MM	38	10 x 8	2.9
SK40MM	40	12 x 8	3.6
SK42MM	42	12 x 8	2.7
SK45MM	45	14 x 9	2.6
SK48MM	48	14 x 9	2.4
SK50MM	50	14 x 9	2.3
SK55MM	55	16 x 10	2.0
<b>SF BUSHINGS</b>			
SF28MM	28	8 x 7	4.7
SF30MM	30	8 x 7	4.6
SF32MM	32	10 x 8	4.5
SF35MM	35	10 x 8	4.4
SF38MM	38	10 x 8	4.2
SF40MM	40	12 x 8	4.2
SF42MM	42	12 x 8	4.1
SF45MM	45	14 x 9	3.9
SF48MM	48	14 x 9	3.7
SF50MM	50	14 x 9	3.6
SF55MM	55	16 x 10	3.2
SF60MM	60	18 x 11	3.0
SF65MM	65	18 x 8 †	2.6
<b>E BUSHINGS</b>			
E35MM	35	10 x 8	10.2
E38MM	38	10 x 8	10.0
E40MM	40	12 x 8	9.9
E42MM	42	12 x 8	9.8
E45MM	45	14 x 9	9.6
E48MM	48	14 x 9	9.3
E50MM	50	14 x 9	9.2
E55MM	55	16 x 10	8.6
E60MM	60	18 x 11	8.1
E65MM	65	18 x 11	7.6
E70MM	70	20 x 12	7.1
E75MM	75	20 x 12	6.9
E80MM	80	22 x 11†	6.3

Product No.	Bore (mm)	Key ■	Wt. (*)
<b>F BUSHINGS</b>			
F45MM	45	14 x 9	16.2
F48MM	48	14 x 9	16.0
F50MM	50	14 x 9	15.8
F55MM	55	16 x 10	15.0
F60MM	60	18 x 11	14.3
F65MM	65	18 x 11	13.7
F70MM	70	20 x 12	12.9
F75MM	75	20 x 12	12.1
F80MM	80	22 x 14	11.2
F85MM	85	22 x 14	10.6
F90MM	90	25 x 14	9.7
<b>J BUSHINGS</b>			
J50MM	50	14 x 9	26.5
J55MM	55	16 x 10	25.6
J60MM	60	18 x 11	24.7
J65MM	65	18 x 11	23.9
J70MM	70	20 x 12	23.0
J75MM	75	20 x 12	21.9
J80MM	80	22 x 14	20.9
J85MM	85	22 x 14	19.3
J90MM	90	25 x 14	18.1
J95MM	95	25 x 14	16.8
J100MM	100	28 x 16	16.5
<b>M BUSHINGS</b>			
M80MM	80	22 x 14	55.0
M90MM	90	25 x 14	51.2
M100MM	100	28 x 16	46.9
M120MM	120	32 x 18	37.0
<b>N BUSHINGS</b>			
N100MM	100	28 x 16	72.3
N120MM	120	32 x 18	60.2
<b>P BUSHINGS</b>			
P150MM	150	36 x 20	95.8

\* Approximate weight in lbs.

■ The metric system does not refer to keyseat or keyway dimensions as does the English system; instead, dimensions are given for the key itself, which is rectangular in shape and not square as in the English system. This meets ISO standards.

† SHALLOW KEY FURNISHED

**“L” SERIES FLANGELESS BUSHINGS**

Bush.	Torque Capacity (In.-Lbs.)	Type Material	Max. Bore (In.)	Max. Bore <sup>†</sup> (mm)	Dimensions in Inches		Bolt Circle	Capscrews Required
					B	F		
SKL	7,000	D.I.	1-15/16	50	2.8125	1-1/8	2-3/8	3-1/4 x 1-1/2
SFL	11,000	D.I.	2-3/8	60	3.1250	1-1/8	2-3/4	4-1/4 x 1-1/2
EL	20,000	D.I.	2-7/8	73	3.8340	1-1/2	3-3/8	4-5/16 x 1-3/4
FL	45,000	D.I.	3-1/8	80	4.4375	2-3/8	3-3/4	4-3/8 x 2

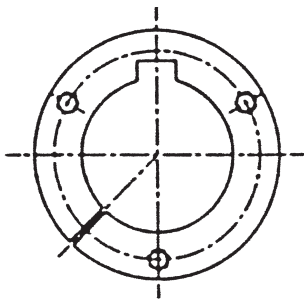
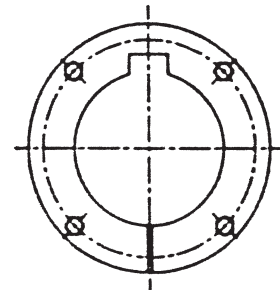
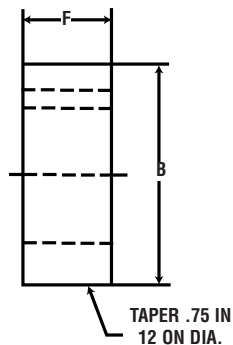
<sup>†</sup> MAX BORE WITH STANDARD KEYSEAT.

**BUSHING  
SKL**

**BUSHINGS  
SFL TO FL**

Patent No. 5304101

**To Install:**
**IMPORTANT: DO NOT USE LUBRICANTS IN THIS INSTALLATION**

1. Inspect shafts, bushing, and mating hub. Remove all nicks, paint, dirt, grease, etc. from mating surfaces.
2. Place key in shaft's keyseat.
3. Slide bushing onto shaft and key. **Small End of Taper Must Be Outboard.**
4. Slide tapered mating hub over bushing. Align (1) the shaft key with one of the slots in the mating hub and (2) the drilled holes in mating hub with the threaded holes in the bushing.
5. Put lockwashers on cap screws and insert one cap screw thru each drilled hole in the mating hub and into the threaded hole in the bushing.
6. **Use a Torque Wrench.** Tighten all cap screws evenly and progressively in rotation. Torque around all the cap screws as often as necessary until the listed torque value remains on each cap screw.

BUSHING	TORQUE (Ft.-Lbs.)
SKL	15
SFL	15
EL	30
FL	55

**CAUTION**  
 The use of lubricants or excessive wrench torques may cause hub stresses high enough to break the mating hub!

**To Remove:**

1. Loosen and remove all cap screws from assembly.
2. Install one cap screw in each threaded hole in the mating hub.
3. Evenly torque each cap screw in rotation to force the mating hub off the bushing.

# SURE-GRIP BUSHINGS BORE AND KEYSEAT DIMENSIONS



An Altra Industrial Motion Company

## “L” SERIES FLANGELESS BUSHINGS

(Inches)

Product No.	Bore	Key Seat	Wt. (*)
<b>SKL BUSHINGS</b>			
SKLMPB	1/2	MPB*	1.7
SKL12	1/2	1/8 x 1/16	1.7
SKL58	5/8	3/16 x 3/32	1.7
SKL34	3/4	3/16 x 3/32	1.6
SKL78	7/8	3/16 x 3/32	1.6
SKL15/16	15/16	1/4 x 1/8	1.6
SKL1	1	1/4 x 1/8	1.6
SKL118	1-1/8	1/4 x 1/8	1.5
SKL1316	1-3/16	1/4 x 1/8	1.4
SKL114	1-1/4	1/4 x 1/8	1.4
SKL1516	1-5/16	5/16 x 5/32	1.3
SKL138	1-3/8	5/16 x 5/32	1.3
SKL1716	1-7/16	3/8 x 3/16	1.2
SKL112	1-1/2	3/8 x 3/16	1.2
SKL1916	1-9/16	3/8 x 3/16	1.2
SKL158	1-5/8	3/8 x 3/16	1.1
SKL11116	1-11/16	3/8 x 3/16	1.1
SKL134	1-3/4	3/8 x 3/16	1.0
SKL11316	1-13/16	1/2 x 1/4	1.0
SKL178	1-7/8	1/2 x 1/4	.9
SKL11516	1-15/16	1/2 x 1/4	.8

\* Approximate weight in lbs.

MPB bushings are unsplit.

Product No.	Bore	Key Seat	Wt. (*)
<b>SFL BUSHINGS</b>			
SFLMPB	1/2	MPB*	2.1
SFL12	1/2	1/8 x 1/16	2.1
SFL58	5/8	3/16 x 3/32	2.1
SFL34	3/4	3/16 x 3/32	2.0
SFL78	7/8	3/16 x 3/32	2.0
SFL15/16	15/16	1/4 x 1/8	2.0
SFL1	1	1/4 x 1/8	2.0
SFL118	1-1/8	1/4 x 1/8	1.9
SFL1316	1-3/16	1/4 x 1/8	1.8
SFL114	1-1/4	1/4 x 1/8	1.8
SFL1516	1-5/16	5/16 x 5/32	1.7
SFL138	1-3/8	5/16 x 5/32	1.7
SFL1716	1-7/16	3/8 x 3/16	1.6

Product No.	Bore	Key Seat	Wt. (*)
<b>SFL BUSHINGS</b>			
SFL112	1-1/2	3/8 x 3/16	1.6
SFL1916	1-9/16	3/8 x 3/16	1.5
SFL158	1-5/8	3/8 x 3/16	1.5
SFL11116	1-11/16	3/8 x 3/16	1.4
SFL134	1-3/4	3/8 x 3/16	1.4
SFL11316	1-13/16	1/2 x 1/4	1.4
SFL178	1-7/8	1/2 x 1/4	1.3
SFL11516	1-15/16	1/2 x 1/4	1.3
SFL2	2	1/2 x 1/4	1.2
SFL218	2-1/8	1/2 x 1/4	1.1
SFL2316	2-3/16	1/2 x 1/4	1.0
SFL214	2-1/4	1/2 x 1/4	1.0
SFL2516	2-5/16	5/8 x 5/16	.9
SFL238	2-3/8	5/8 x 5/16	.9

Product No.	Bore	Key Seat	Wt. (*)
<b>EL BUSHINGS</b>			
ELMPB	7/8	MPB*	4.1
EL78	7/8	3/16 x 3/32	4.1
EL15/16	15/16	1/4 x 1/8	4.0
EL1	1	1/4 x 1/8	3.9
EL118	1-1/8	1/4 x 1/8	3.8
EL1316	1-3/16	1/4 x 1/8	3.8
EL114	1-1/4	1/4 x 1/8	3.7
EL1516	1-5/16	5/16 x 5/32	3.6
EL138	1-3/8	5/16 x 5/32	3.6
EL1716	1-7/16	3/8 x 3/16	3.5
EL112	1-1/2	3/8 x 3/16	3.5
EL1916	1-9/16	3/8 x 3/16	3.4
EL158	1-5/8	3/8 x 3/16	3.4
EL11116	1-11/16	3/8 x 3/16	3.3
EL134	1-3/4	3/8 x 3/16	3.2
EL11316	1-13/16	1/2 x 1/4	3.2
EL178	1-7/8	1/2 x 1/4	3.1
EL11516	1-15/16	1/2 x 1/4	3.0
EL2	2	1/2 x 1/4	3.0
EL218	2-1/8	1/2 x 1/4	2.9
EL2316	2-3/16	1/2 x 1/4	2.8
EL214	2-1/4	1/2 x 1/4	2.7
EL2516	2-5/16	5/8 x 5/16	2.6
EL238	2-3/8	5/8 x 5/16	2.5
EL2716	2-7/16	5/8 x 5/16	2.4

Product No.	Bore	Key Seat	Wt. (*)
<b>EL BUSHINGS</b>			
EL212	2-1/2	5/8 x 5/16	2.3
EL2916	2-9/16	5/8 x 5/16	2.3
EL258	2-5/8	5/8 x 5/16	2.2
EL21116	2-11/16	5/8 x 5/16	2.1
EL234	2-3/4	5/8 x 5/16	2.0
EL21316	2-13/16	3/4 x 3/8	1.9
EL278	2-7/8	3/4 x 3/8	1.8

Product No.	Bore	Key Seat	Wt. (*)
<b>FL BUSHINGS</b>			
FLMPB	1	MPB*	8.5
FL1	1	1/4 x 1/8	8.5
FL118	1-1/8	1/4 x 1/8	8.3
FL1316	1-3/16	1/4 x 1/8	8.2
FL114	1-1/4	1/4 x 1/8	8.1
FL138	1-3/8	5/16 x 5/32	8.0
FL1716	1-7/16	3/8 x 3/16	7.9
FL112	1-1/2	3/8 x 3/16	7.8
FL1916	1-9/16	3/8 x 3/16	7.6
FL158	1-5/8	3/8 x 3/16	7.5
FL11116	1-11/16	3/8 x 3/16	7.4
FL134	1-3/4	3/8 x 3/16	7.3
FL178	1-7/8	1/2 x 1/4	7.1
FL11516	1-15/16	1/2 x 1/4	7.0
FL2	2	1/2 x 1/4	6.7
FL218	2-1/8	1/2 x 1/4	6.6
FL2316	2-3/16	1/2 x 1/4	6.5
FL214	2-1/4	1/2 x 1/4	6.4
FL2516	2-5/16	5/8 x 5/16	6.3
FL238	2-3/8	5/8 x 5/16	6.2
FL2716	2-7/16	5/8 x 5/16	6.1
FL212	2-1/2	5/8 x 5/16	5.9
FL2916	2-9/16	5/8 x 5/16	5.7
FL258	2-5/8	5/8 x 5/16	5.6
FL21116	2-11/16	5/8 x 5/16	5.4
FL234	2-3/4	5/8 x 5/16	5.3
FL21316	2-13/16	3/4 x 3/8	5.1
FL278	2-7/8	3/4 x 3/8	4.9
FL21516	2-15/16	3/4 x 3/8	4.8
FL3	3	3/4 x 3/8	4.6
FL318	3-1/8	3/4 x 3/8	4.5

Sure-Grip bushings are designed to transmit the rated torque capacity listed in the table below when the cap screws are tightened as indicated. The bushings are stocked in all popular bore sizes, including metric bores, within bore range for a particular bushing.

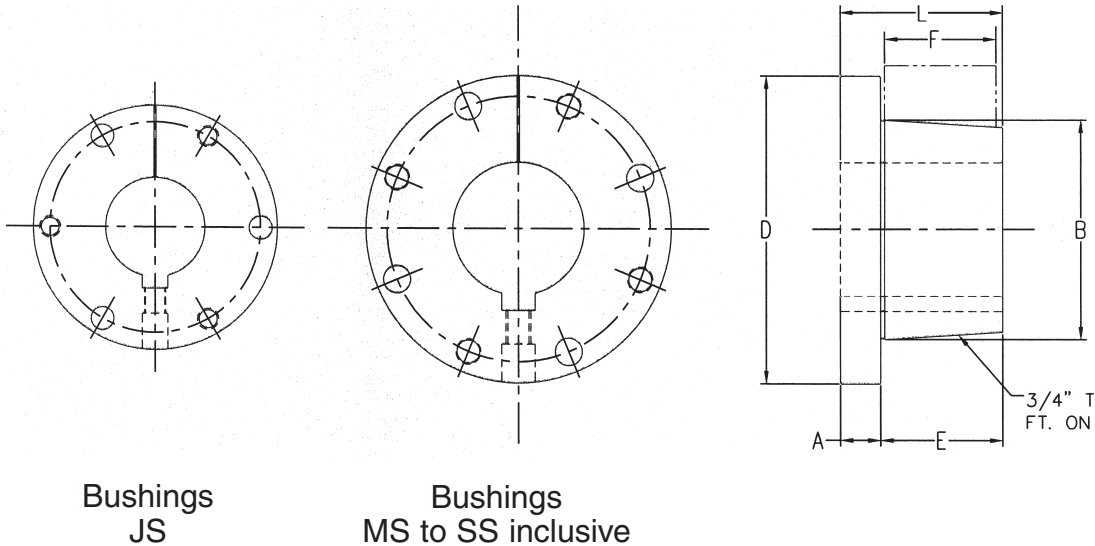

**SURE-GRIP SHORT  
BUSHING TORQUE RATINGS  
AND DIMENSIONS**

Bush.	Torque Capacity (In.-Lbs.)	Max Bore	DIMENSIONS IN INCHES					Bolt Circle	Cap Screws Required
			A	B	D	E	L		
JS	55,000	4-1/2	1	5.1484	7-1/4	2-3/8	3-3/8	6-1/4	3-5/8 x 2-1/2
MS	125,000	5-1/2	1-3/16	6.500	9-1/8	3-5/8	4-13/16	7-7/8	4-3/4 x 3
NS	150,000	6	1-1/2	7.000	10	4-1/2	6	8-1/2	4-7/8 x 3-1/2
PS	250,000	7	1-1/2	8.250	11-3/4	5	6-1/2	10	4 - 1 x 4
WS	375,000	8-1/2	1-3/4	10.437	15	5-1/2	7-1/4	12-3/4	4 - 1-1/8 x 5
SS	625,000	10	2	12.125	17-3/4	6-3/4	8-3/4	15	5 - 1-1/4 x 5

Setscrew not standard – Available as alteration.

See page A1-11 for Bore and Keyseat information and weights.

# SURE-GRIP SHORT BUSHINGS BORE AND KEYSEAT DIMENSIONS

(Inches)

Product No.	Bore	Key Seat	Wt. (*)
<b>JS BUSHINGS</b>			
JS2716	2- 7/16	5/8 X 5/16	20.0
JS21516	2-15/16	3/4 X 3/8	18.1
JS3716	3- 7/16	7/8 X 7/16	15.9
JS31516	3-15/16	1 X 1/4	14.3
JS4716	4- 7/16	1 X 1/8	11.5

Product No.	Bore	Key Seat	Wt. (*)
<b>MS BUSHINGS</b>			
MS3716	3- 7/16	7/8 X 7/16	41.2
MS31516	3-15/16	1 X 1/2	37.3
MS4716	4- 7/16	1 X 1/2	33.3
MS41516	4-15/16	1-1/4 X 1/4	30.9
MS5716	5- 7/16	1-1/4 X 1/4	25.9

Product No.	Bore	Key Seat	Wt. (*)
<b>NS BUSHINGS</b>			
NS31516	3-15/16	1 X 1/2	66.3
NS4716	4- 7/16	1 X 1/2	52.5
NS41516	4-15/16	1-1/4 X 5/8	46.5
NS5716	5- 7/16	1-1/4 X 1/4	43.9
NS51516	5-15/16	1-1/2 X 1/8	39.0
NS6	6	1-1/2 X 1/8	38.8

Product No.	Bore	Key Seat	Wt. (*)
<b>PS BUSHINGS</b>			
PS41516	4-15/16	1-1/4 X 5/8	88.3
PS5716	5- 7/16	1-1/4 X 5/8	81.3
PS51516	5-15/16	1-1/2 X 3/4	78.4
PS6	6	1-1/2 X 3/4	77.4
PS6716	6- 7/16	1-1/2 X 1/2	70.0
PS612	6- 1/2	1-1/2 X 1/2	69.0
PS61516	6-15/16	1-3/4 X 1/8	61.3
PS7	7	1-3/4 X 1/8	60.4

Product No.	Bore	Key Seat	Wt. (*)
<b>WS BUSHINGS</b>			
WS5716	5- 7/16	1-1/4 X 5/8	172.3
WS51516	5-15/16	1-1/2 X 3/4	161.1
WS6716	6- 7/16	1-1/2 X 3/4	155.0
WS612	6- 1/2	1-1/2 X 3/4	153.0
WS61516	6-15/16	1-3/4 X 3/4	140.0
WS7	7	1-3/4 X 3/4	139.0
WS712	7- 1/2	1-3/4 X 3/4	137.0
WS71516	7-15/16	2 X 3/4	126.9
WS8	8	2 X 3/4	124.0
WS8716	8- 7/16	2 X 1/4	107.3
WS812	8- 1/2	2 X 1/4	105.0

\* Approximate weight in lbs.

# DOUBLE ADJUSTMENT TENSIONER BELT DRIVE OR CHAIN TENSIONER

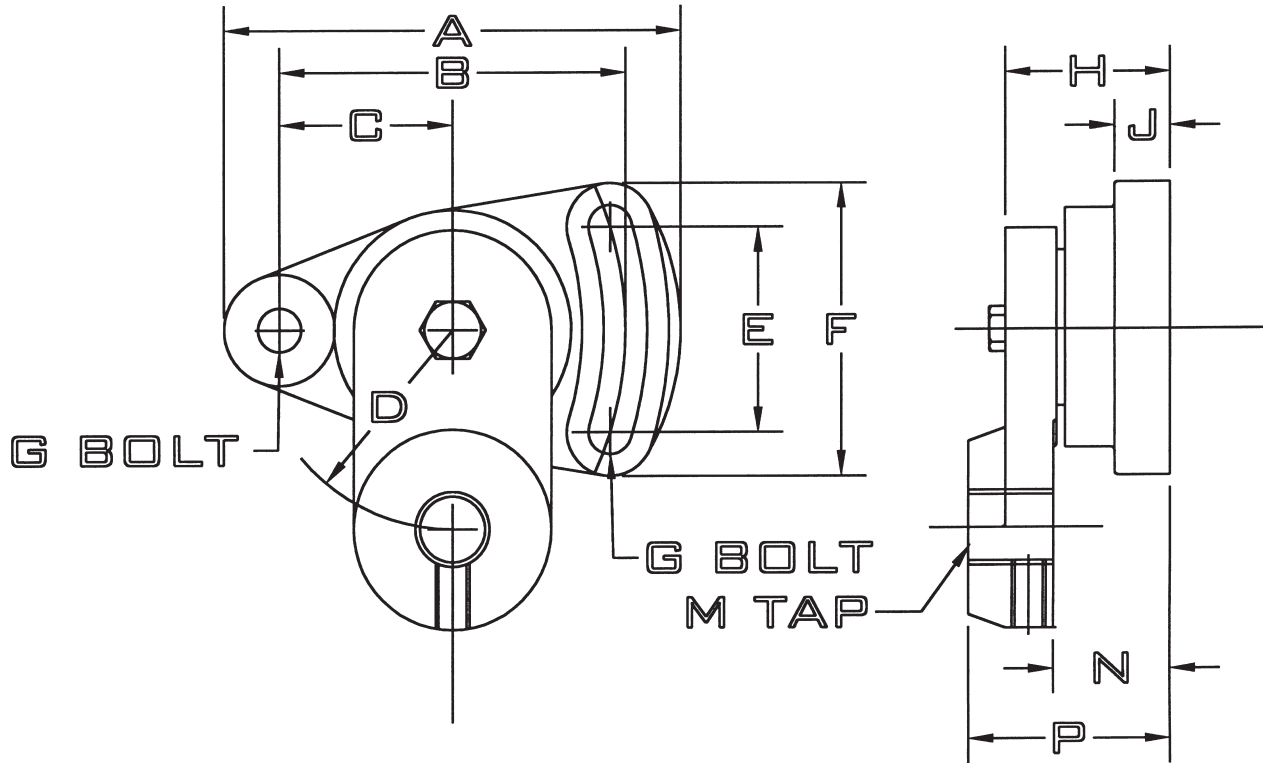

Product Number	DIMENSIONS IN INCHES												Weight Lbs.
	A	B	C	D	E	F	G	H	J	M	N	P	
<b>DAM</b>	4.62	3.50	1.75	2.00	2.06	3.06	.375	1.63	.62	3/4-10	1.16	2.01	3.0
<b>DAL</b>	6.94	5.25	2.63	5.00	3.00	4.56	.625	2.38	.88	1"-8	1.68	2.94	9.5

The Double Adjustment tensioner (Type DA) permits a full 360 degree rotation of the idler. A second adjustment is obtained by the long slot in the base. The arm is locked in place with an ingenious use of a tapered fit. Tensioning of a drive should follow the installation guideline for the type of drive in question.



# SURE-GRIP IDLER BUSHINGS



An Altra Industrial Motion Company

## FOR USE WITH SHEAVES, PULLEYS, SPROCKETS, GEARS OR OTHER PRODUCTS DESIGNED FOR QD-TYPE BUSHINGS



Wood's Sure-Grip Idler Bushings are designed to accommodate stock V-belt sheaves, flat-belt or Timing-belt pulleys, roller or silent chain sprockets, gears or other products that use QD\*-type bushings. They are equipped with two, permanently lubricated, ball-bearing units for long, smooth, trouble-free performance. Installation is made simply by slipping the threaded shaft through a hole bored in the support structure and tightening the locking nut. Sheaves, pulleys or other products can be removed without dismantling the idler bushing. These idler units are available with SH, SD, SK, SF or E Sure-Grip bushings. Wood's Sure-Grip bushings are of the most widely used, tapered, interchangeable type.

\* U.S.T.M. Reg. No. 403,470    Can. T.M. Reg. No. 113,711

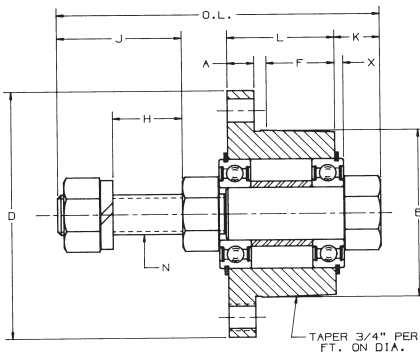

Product No.	DIMENSIONS											Wt. (Lbs.)
	A	B	D	F	H	J	K	L	N	O.L.	X	
SHBB	0.38	1.871	2.69	0.75	.53	0.98	0.44	1.25	1/2-13NC	3.13	.12	1.5
SDBB	0.44	2.187	3.19	1.25	.72	1.17	0.44	1.81	1/2-13NC	3.88	.12	2.5
SDBB58	0.44	2.187	3.19	1.25	.57	1.12	0.44	1.81	5/8-11NC	3.88	.12	2.7
SKBB	0.50	2.812	3.88	1.25	.85	1.42	0.62	1.88	3/4-10NC	4.50	.14	4.5
SFBB	0.50	3.125	4.63	1.38	.73	1.29	0.62	2.00	3/4-10NC	4.50	.14	8.0
SFBB1	0.50	3.125	4.63	1.38	1.08	1.91	0.62	2.00	1"-8NC	5.25	.14	8.6
EBB	0.75	3.834	6.00	1.63	1.11	2.30	0.97	2.63	1-3/8-6NC	6.88	.19	12.0

### Equivalent Load Rating (lbs.)

Hours Life	Product No.	Basic Rating	RPM					
			500	1000	2000	3000	4000	5000
1000	SHBB	3320	1068	848	673	588	534	496
	SKBB	4860	1564	1241	985	861	782	726
	SFBB	4860	1564	1241	985	861	782	726
	EBB	10100	3250	2580	2048	1789	1625	1509
2000	SHBB	3320	848	673	534	467	424	394
	SDBB	3320	848	673	534	467	424	394
	SKBB	4860	1241	985	782	683	621	576
	SFBB	4860	1241	985	782	683	621	576
6000	EBB	10100	2580	2048	1625	1420	1290	1197
	SHBB	3320	588	467	370	324	294	273
	SDBB	3320	588	467	370	324	294	273
	SKBB	4860	861	683	542	474	430	400
	SFBB	4860	861	683	542	474	430	400
	EBB	10100	1789	1420	1127	984	894	830

**Note:** The basic rating is the maximum dynamic radial load which will allow a 90% survival rate when running at 33-1/3 RPM for 500 hours.

$$\text{Equivalent Rating} = \sqrt[3]{\frac{\text{Basic Rating}}{\text{Hours} \times 60 \times \text{RPM} / 1,000,000}}$$

$$\text{Hours} = \frac{\text{Basic Rating}^3 \times 1,000,000}{\text{Load (Lbs.)}^3 \times 60 \times \text{RPM}}$$

# SURE-GRIP BUSHINGS INSTALLATION INSTRUCTIONS

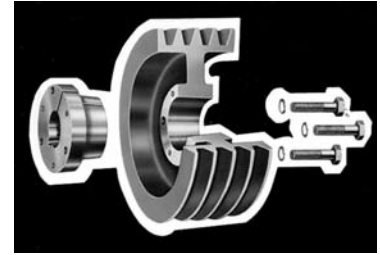

The Sure-Grip tapered, QD-type interchangeable bushing offers flexible and easy installation while providing exceptional holding power. To ensure that the bushing performs as specified, it must be installed properly.

Before beginning, make sure the correct size and quantity of parts are available for the installation. The bushing has been manufactured to accept a setscrew over the key and its use is optional. It is packaged with the hardware on sizes SH to M and loosely installed in the bushing on sizes N to S.

## To Install:

### IMPORTANT:

#### DO NOT USE LUBRICANTS IN THIS INSTALLATION!

1. Inspect the tapered bore of the sheave and the tapered surface of the bushing. Any paint, dirt, oil, or grease **MUST** be removed.
2. Select the type of mounting (See Fig. 1 or 2) that best suits your application.

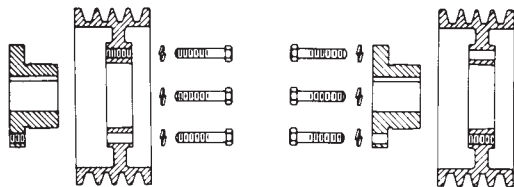

3. **STANDARD MOUNTING:** Install shaft key. (Note: If key was furnished with bushing, you must use that key.) Install bushing on clean shaft, flange end first. If bushing will not freely slide on the shaft, insert a screwdriver or similar object into the flange sawcut to act as a wedge to open the bushing's bore. **Caution: Excessive wedging will split the bushing.** If using the setscrew, tighten it just enough to prevent the bushing from sliding on the shaft. **Caution: Do not over-tighten setscrew!** Slide sheave into position on bushing aligning the drilled holes in the sheave with the tapped holes in the bushing flange. (Note: Install M thru S bushings so that the two tapped holes in the sheave are located as far away as possible from the bushing's sawcut.) Loosely thread the capscrews with lockwashers into the assembly. **DO NOT USE LUBRICANT ON THE CAPSCREWS!**

4. **REVERSE MOUNTING:** With large end of the taper out, slide sheave onto shaft as far as possible. Install shaft key. (See shaft key note in #3 above.) Install bushing onto shaft so tapered end will mate with sheave. (See wedging note in #3 above.) If using the setscrew, tighten it enough to prevent the bushing from sliding on the shaft. **Caution: Do not over-tighten setscrew!** Pull the sheave up on the bushing, aligning the drilled holes in the bushing flange with the tapped holes in the sheave. Loosely thread the capscrews with lockwashers into the assembly. **DO NOT USE LUBRICANT ON THE CAPSCREWS!**

5. Using a torque wrench, tighten all capscrews evenly and progressively in rotation to the torque value in Table. There must be a gap between the bushing flange and sheave hub when installation is complete. **DO NOT OVER-TORQUE! DO NOT ATTEMPT TO CLOSE GAP BETWEEN BUSHING FLANGE AND SHEAVE HUB!**

## To Remove:

1. Relieve drive tension by shortening the center distance between driver and driven sheaves.
2. Lift off belts.
3. Loosen and remove cap screws. If the bushings have keyway setscrews, loosen them.
4. As shown below, insert cap screws (three in JA through J bushings, two in QT and M thru W bushings and four in S bushing) in tapped removal holes and progressively tighten each one until mating part is loose on bushing. (Exception: If mating part is installed with cap screw heads next to motor, with insufficient room to insert screws in tapped holes, loosen cap screws and use wedge between bushing flange and mating part.)
5. Remove mating part from bushing and, if necessary, bushing from shaft.

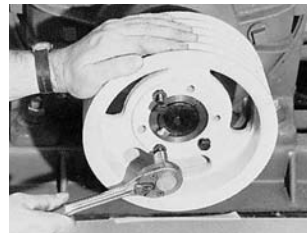

### SURE-GRIP BUSHINGS SCREW TIGHTENING INFORMATION

Tapered Bushing	Size & Thread of Cap Screw	Ft.-Lbs. To Apply With Torque Wrench
QT	1/4 x 20	9
JA	No. 10 - 24	5
SH-SDS-SD	1/4 - 20	9
SK	5/16 - 18	15
SF	3/8 - 16	30
E	1/2 - 13	60
F	9/16 - 12	110
J	5/8 - 11	135
M	3/4 - 10	225
MS	3/4 - 10	150
N	7/8 - 9	300
NS	7/8 - 9	200
P	1 - 8	450
PS	1 - 8	300
W	1-1/8 - 7	600
WS	1-1/8 - 7	400
S	1-1/4 - 7	750
SS	1-1/4 - 7	500

**CAUTION:** The tightening force on the screws is multiplied many times by the wedging action of the tapered surface. If extreme tightening force is applied, or if a lubricant is used, bursting pressures will be created in the hub of the mating part.

# TB Wood's

TB Wood's offers a comprehensive selection of belts and sheaves designed to meet the needs of a wide variety of industrial applications.

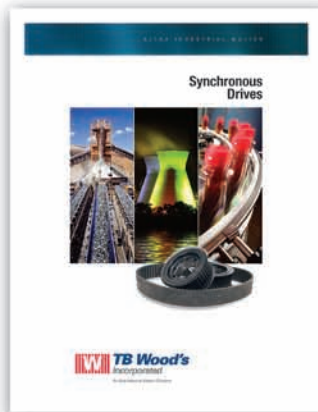

## Synchronous Drives

TB Wood's synchronous drives combine the best of both chain and belted drives. These drives can withstand the harshest environmental conditions and are also available in a washdown version. TB Wood's synchronous drives are low noise, and are perfect for many high-speed, low torque applications.

See Catalog P-1691-TBW

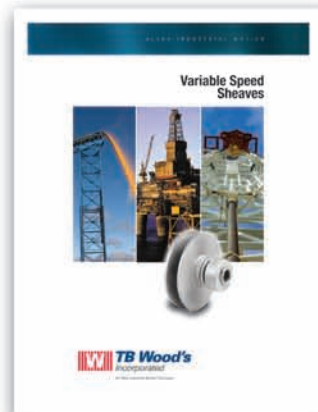

## Variable Speed Sheaves

TB Wood's offers a wide range of companion sheaves for motion control variable speed drives that are made to accommodate Sure-Grip® Bushings for ease of installation. A wide range of companion pulleys are also available.

See Catalog P-1689-TBW

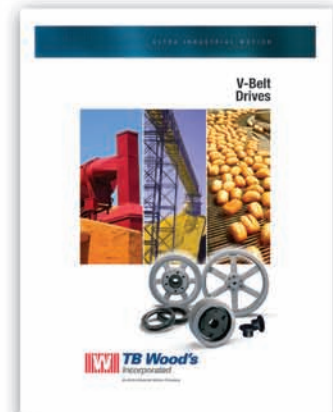

## V-Belt Drives

TB Wood's has been known as the "Large Sheave" experts offering up to 108 inch maximum capacity sheaves. TB Wood's is known for superior response time on stock and made-to-order sheaves due to an integrated foundry. Value-added services including, kitting and drive selection software, put TB Wood's at the top of the list.

See Catalog P-1687-TBW

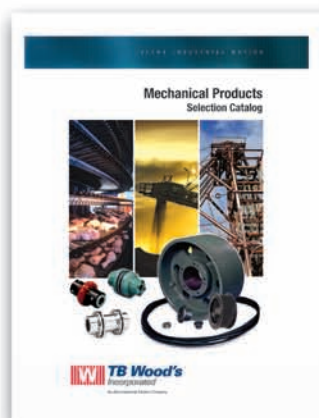

## Mechanical Products

Our Mechanical Products Selection Catalog is a comprehensive overview of TB Wood's products. From V-Belts to Sheaves and Couplings, this catalog encompasses all that TB Wood's has to offer.

See Catalog P-1686-TBW

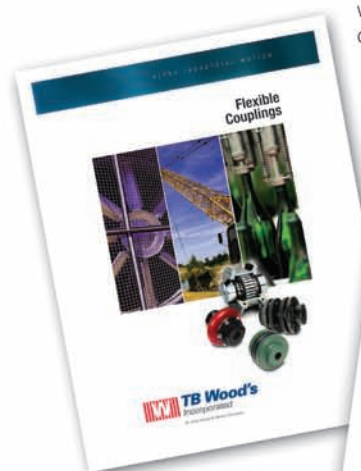

## Flexible Couplings

See Catalog P-1690-TBW

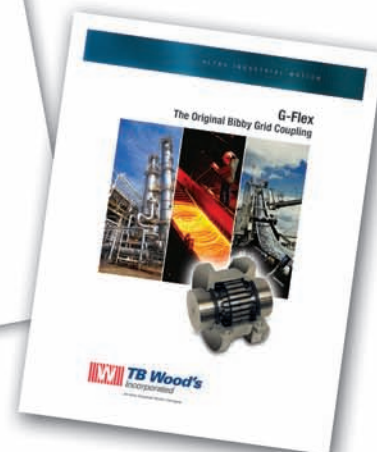

## G-Flex Couplings

See Catalog P-1674-TBW

## TB Wood's Couplings

TB Wood's offers a complete line of couplings for any coupling application with several lines of high performance couplings.

All Customer Service phone numbers shown in bold

## Electromagnetic Clutches and Brakes

### Warner Electric

*Electromagnetic Clutches and Brakes*

New Hartford, CT - USA  
**1-800-825-6544**

*For application assistance:*  
1-800-825-9050

St Barthelemy d'Anjou, France  
**+33 (0) 2 41 21 24 24**

*Precision Electric Coils and Electromagnetic Clutches and Brakes*

Columbia City, IN - USA  
**1-260-244-6183**

### Matrix International

*Electromagnetic Clutches and Brakes, Pressure Operated Clutches and Brakes*

Brechin, Scotland  
**+44 (0) 1356 602000**

New Hartford, CT - USA  
**1-800-825-6544**

### Inertia Dynamics

*Spring Set Brakes; Power On and Wrap Spring Clutch/Brakes*

New Hartford, CT - USA  
**1-800-800-6445**

## Overrunning Clutches

### Formsprag Clutch

*Overrunning Clutches and Holdbacks*

Warren, MI - USA  
**1-800-348-0881** – Press #1

*For application assistance:*  
1-800-348-0881 – Press #2

### Marland Clutch

*Roller Ramp and Sprag Type Overrunning Clutches and Backstops*

Burr Ridge, IL - USA  
**1-800-216-3515**

### Stieber Clutch

*Overrunning Clutches and Holdbacks*

Heidelberg, Germany  
**+49 (0) 6221 30 47 0**

## Engineered Couplings

### Ameridrives Couplings

*Mill Spindles, Ameriflex, Ameridisc*

Erie, PA - USA  
**1-814-480-5000**

*Gear Couplings*

San Marcos, TX - USA  
**1-512-353-4000**

### Bibby Transmissions

*Disc, Gear, Grid Couplings, Overload Clutches*

Dewsbury, England  
**+44 (0) 1924 460801**

Boksburg, South Africa  
**+27 11 918 4270**

### TB Wood's

*Elastomeric Couplings*

Chambersburg, PA - USA  
**1-888-829-6637** – Press #5

*For application assistance:*  
1-888-829-6637 – Press #7

*General Purpose*

*Disc Couplings*

San Marcos, TX - USA  
**1-512-353-4000**

### Ameridrives Power Transmission

*Universal Joints, Drive Shafts, Mill Gear Couplings*

Green Bay, WI - USA  
**1-920-593-2444**

### Huco Dynatork

*Precision Couplings and Air Motors*

Hertford, England  
**+44 (0) 1992 501900**

Charlotte, NC - USA  
**1-800-825-6544**

## Linear Products

### Warner Linear

*Linear Actuators and Guideways*

Belvidere, IL - USA  
**1-800-825-6544**

*For application assistance:*  
1-800-825-9050

St Barthelemy d'Anjou, France  
**+33 (0) 2 41 21 24 24**

## Heavy Duty Clutches and Brakes

### Wichita Clutch

*Pneumatic Clutches and Brakes*

Wichita Falls, TX - USA  
**1-800-964-3262**

Bedford, England  
**+44 (0) 1234 350311**

### Twiflex Limited

*Caliper Brakes and Thrusters*

Twickenham, England  
**+44 (0) 20 8894 1161**

### Industrial Clutch

*Pneumatic and Oil Immersed Clutches and Brakes*

Waukesha, WI - USA  
**1-262-547-3357**

## Gearing

### Boston Gear

*Enclosed and Open Gearing, Electrical and Mechanical P.T. Components*

Charlotte, NC - USA  
**1-800-825-6544**

*For application assistance:*  
1-800-816-5608

### Nuttall Gear and Delroyd Worm Gear

*Worm Gear and Helical Speed Reducers*

Niagara Falls, NY - USA  
**1-716-298-4100**

## Belted Drives and Sheaves

### TB Wood's

*Belted Drives*

Chambersburg, PA - USA  
**1-888-829-6637** – Press #5

*For application assistance:*  
1-888-829-6637 – Press #7

## Engineered Bearing Assemblies

### Kilian Manufacturing

*Engineered Bearing Assemblies*

Syracuse, NY - USA  
**1-315-432-0700**

## Asia Pacific Sales Offices

### Australia

Unit 51/9, Hoyle Avenue  
Castle Hill, NSW 2154  
**+61 2 9894 0133**  
**+61 2 9894 0368** (Fax)  
[www.warnerelectric.com.au](http://www.warnerelectric.com.au)

### China - Hong Kong

Room 304A, 3rd Floor  
Join-In Hang Sing Centre  
71-75 Container Port Rd.  
Kwai Chung, Hong Kong  
**+852 2615 9313**  
**+852 2615 9162** (Fax)  
[www.warnerelectric.com.hk](http://www.warnerelectric.com.hk)

### China - Shanghai

Shanghai Universal Mansion  
Suite 703, 168 Yuyuan Road,  
Shanghai 200040  
**+86 21 5169-9255**  
**+86 21 6248 5387** (Fax)  
[www.altramotion.com.cn](http://www.altramotion.com.cn)

### China - Taiwan

3rd Fl., No. 35, Lane 32  
Kwang-Fu, South Road  
10562 Taipei  
**+886 2 2577 8156**  
**+886 2 2570 6358** (Fax)  
[www.warnerelectric.com.tw](http://www.warnerelectric.com.tw)

### Singapore

39 Benoi Road  
Singapore 627725  
**+65 6487 4464**  
**+65 6487 6674** (Fax)  
[www.warnerelectric.com.sg](http://www.warnerelectric.com.sg)

### Thailand

178 Soi Anamai Srinakaran Rd.,  
Suanluang Bangkok 10250  
**+66 2 322 5527**  
**+66 2 320 2380** (Fax)  
[www.warnerelectric.co.th](http://www.warnerelectric.co.th)

For more information, or to contact authorized agents in Japan, Korea, India, or elsewhere in Asia Pacific, send an email to: [ap@altramotion.com](mailto:ap@altramotion.com)



An Altra Industrial Motion Company

[www.tbwoods.com](http://www.tbwoods.com)

440 North Fifth Avenue  
Chambersburg, PA 17201 - USA  
888-829-6637 • 717-264-7161  
Fax: 717-264-6420